

V _{RSM} V _{RRM}	I _{FRMS} (maximum values for continuous operation)		
	10 A	10 A	10 A
	I _{FAV} (sin. 180; T _{ref} = 105 °C, L = 10 mm; f ≤ 1 kHz)		
V	3,8 A	3,4 A	3,8 A
100	SK 3 GF 01	SK 3 GH 01	–
200	SK 3 GF 02	SK 3 GH 02	SK 3 GL 02
400	SK 3 GF 04	SK 3 GH 04	SK 3 GL 04
600	SK 3 GF 06	SK 3 GH 06	SK 3 GL 06
800	–	SK 3 GH 08	SK 3 GL 08
1000	–	SK 3 GH 10*	SK 3 GL 10

Fast Recovery Rectifier Diodes

SK 3 GF
SK 3 GH
SK 3 GL

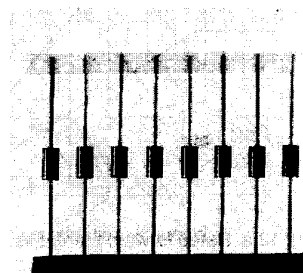

Symbol	Conditions	SK 3 GF	SK 3 GH	SK 3 GL	Units
I _{FAV}	T _{ref} = 100 °C; L = 10 mm; sin./rec. 180	3,3 ¹⁾	3 ²⁾	3,25 ³⁾	A
	T _{amb} = 45 °C; sin./rec. 180; R _{thja} = 60 °C/W	1,7 ¹⁾	1,5 ²⁾	1,6 ³⁾	A
I _{FSM}	T _{vj} = 25 °C; t = 10 ms		175		A
	T _{vj} = 175 °C; t = 10 ms t = 8,3 ms		130 145		A A
i ² t	T _{vj} = 25 °C; 8,3 ... 10 ms T _{vj} = 175 °C; 8,3 ... 10 ms		150 85		A ² s A ² s
Q _{rr}	T _{vj} = 150 °C; I _{FM} = 20 A; – di _F /dt = 100 A/μs; V _R = 100 V; max.	2,2	6	10	μC
I _{RM}		14	21	28	A
t _{rr}	T _{vj} = 25 °C; I _{FM} = 0,5 A; I _{RM} = 1 A; i _{rr} = 0,25 A; max.	80	150	300	ns
t _{fr}	T _{vj} = 25 °C; I _{FM} = 2 A; di _F /dt = 100 A / μs; typ.	100	500	500	ns
I _R	T _{vj} = 25 °C; V _R = V _{RRM} ; max.	5	5	5	μA
	T _{vj} = 150 °C; V _R = V _{RRM} ; typ.	500	500	500	μA
V _F	T _{vj} = 25 °C; I _F = 3 A; max.	1,25	1,4	1,3	V
V _(TO)	T _{vj} = 175 °C	0,85	0,95	0,95	V
r _T	T _{vj} = 175 °C	50	60	40	mΩ
R _{thjr}	L = 10 mm	14			°C/W
R _{thja}	p.c.b. 50 x 50 mm	60			°C
T _{vj}		– 40 ... + 175			°C
T _{stg}		– 55 ... + 175			°C
T _{solder}	max. 10 s, L = 9 mm	280			°C
a		5 · 9,81			m/s ²
w	approx.	1			g
Case		E 29			

Features

- Axial lead diodes, taped
- Glass passivated silicon chip
- Void-free moulded plastic acc. to Underwriters Laboratory (UL) flammability classification 94 V-0
- Polarity: Band denotes cathode terminal
- Peak inverse voltage up to 1000 V
- High surge current of 175 A
- Available with formed leads on request

Typical Applications

- Switched mode power supplies
- TV sets
- Inverters
- Ultrasonic generators
- For printed circuit board mounting

¹⁾ f ≤ 50 kHz

²⁾ f ≤ 30 kHz

³⁾ f ≤ 15 kHz

* Available in limited quantities

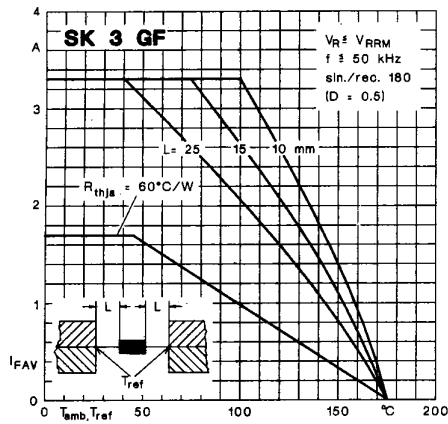

Fig. 12 a Rated forward current vs. temperature

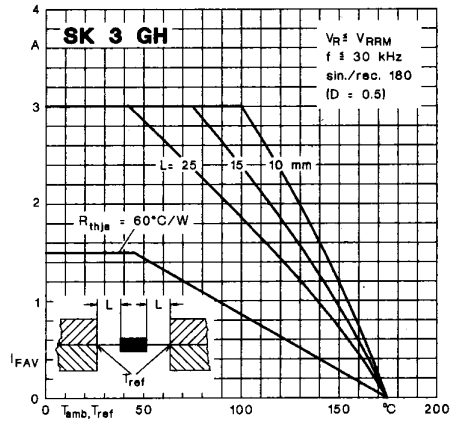

Fig. 12 b Rated forward current vs. temperature

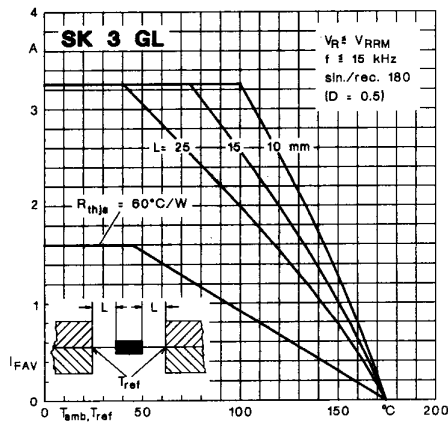

Fig. 12 c Rated forward current vs. temperature

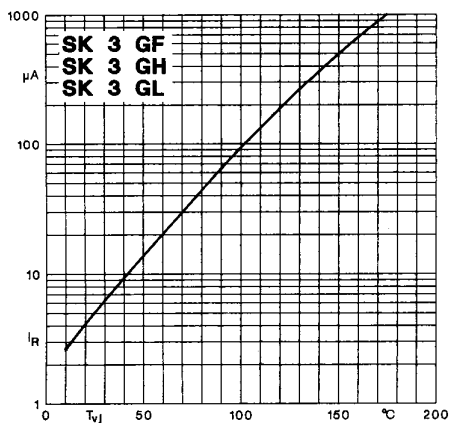
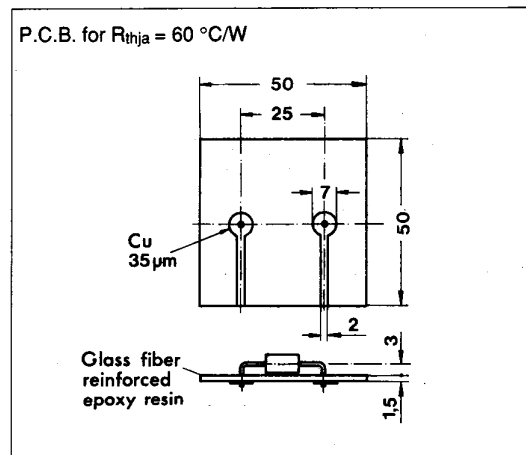

Fig. 13 Reverse current vs. junction temperature

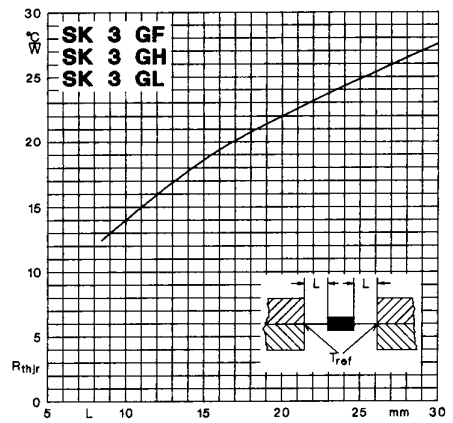

Fig. 14 Thermal resistance vs. lead length

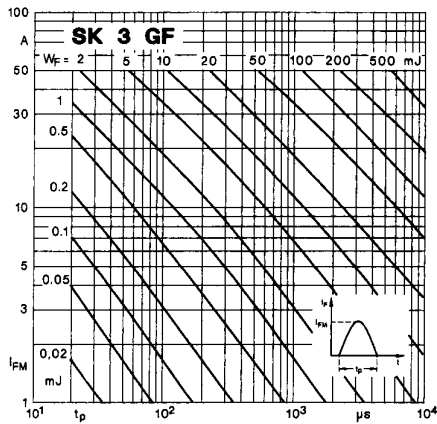

Fig. 2 a Forward energy dissipation, sinusoidal

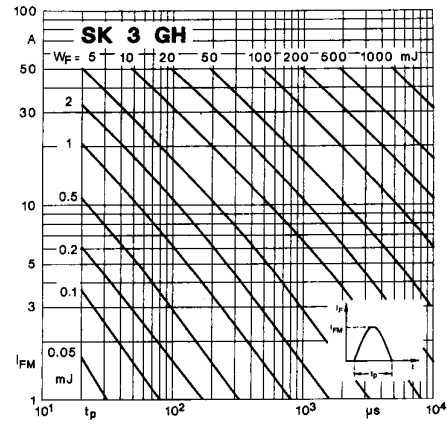

Fig. 2 b Forward energy dissipation, sinusoidal

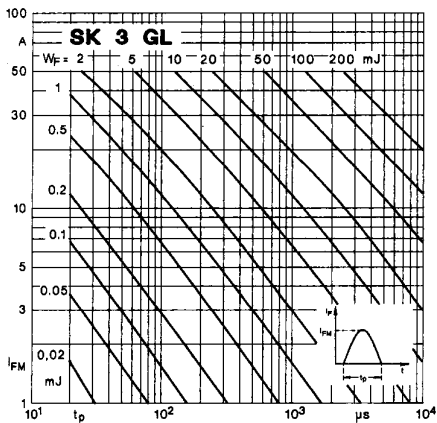

Fig. 2 c Forward energy dissipation, sinusoidal

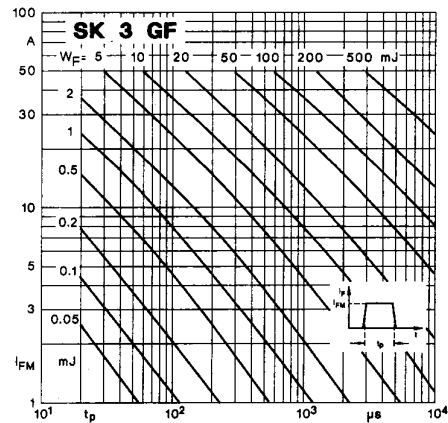

Fig. 4 a Forward energy dissipation, rectangular

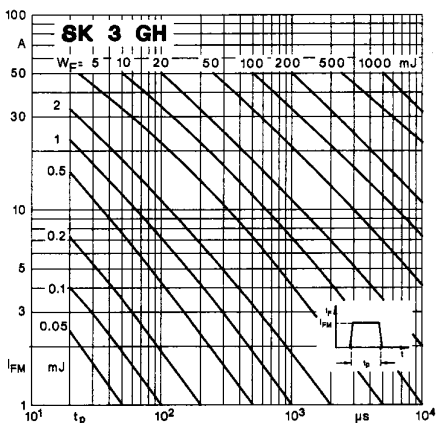

Fig. 4 b Forward energy dissipation, rectangular

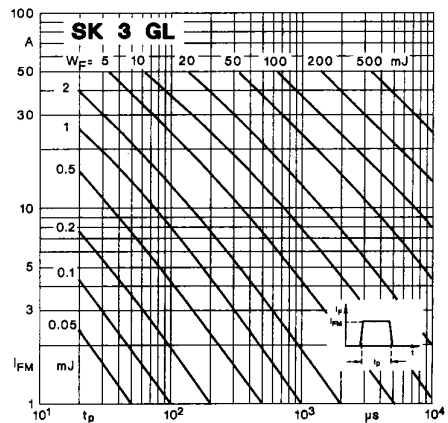

Fig. 4 c Forward energy dissipation, rectangular

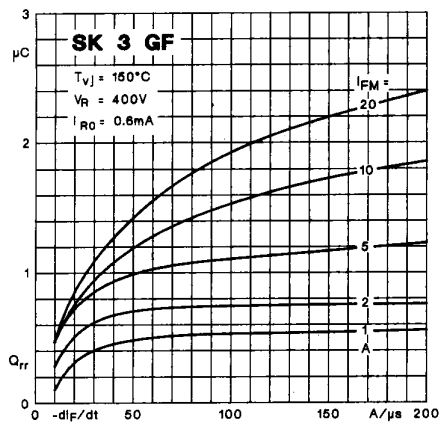

Fig. 5 a Recovered charge

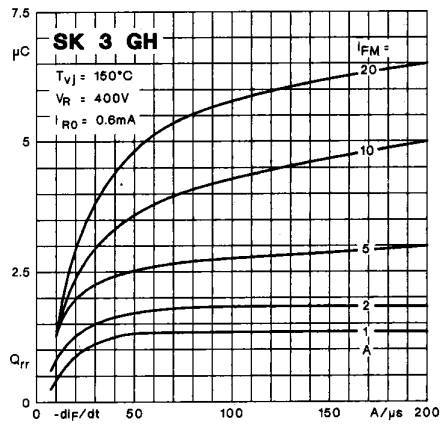

Fig. 5 b Recovered charge

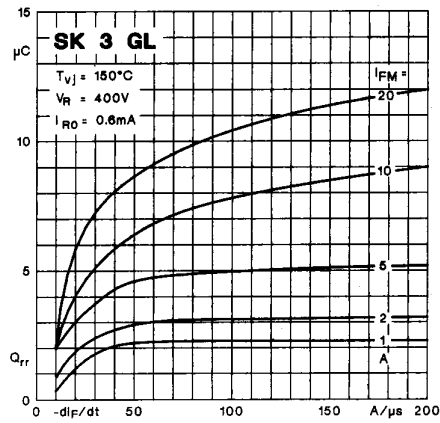

Fig. 5 c Recovered charge

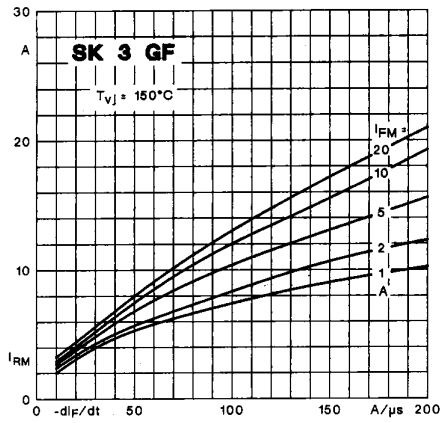

Fig. 6 a Peak reverse recovery current

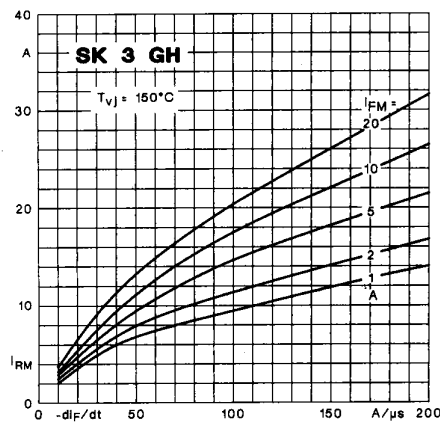

Fig. 6 b Peak reverse recovery current

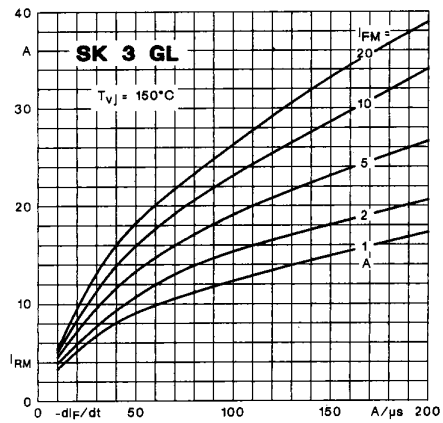

Fig. 6 c Peak reverse recovery current

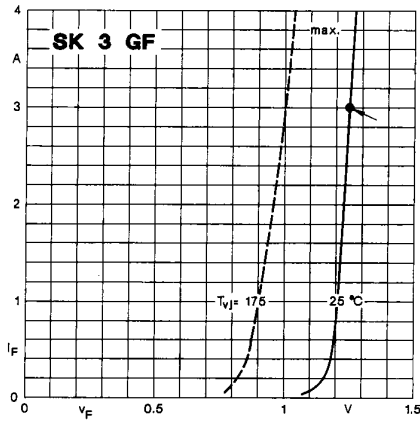

Fig. 8 a Forward characteristics

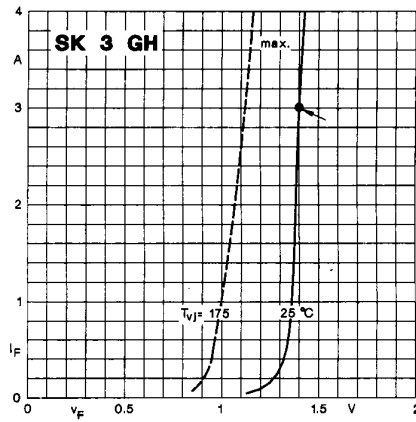

Fig. 8 b Forward characteristics

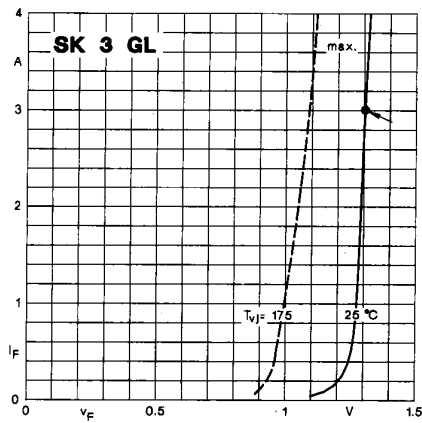

Fig. 8 c Forward characteristics

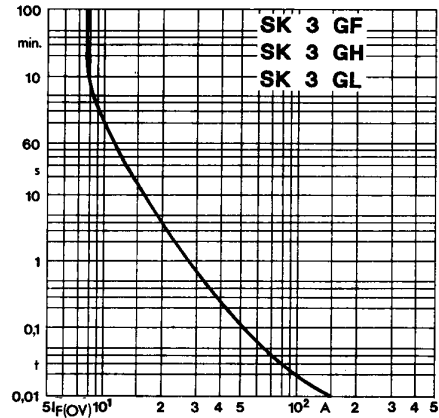

Fig. 11 Rated surge overload current

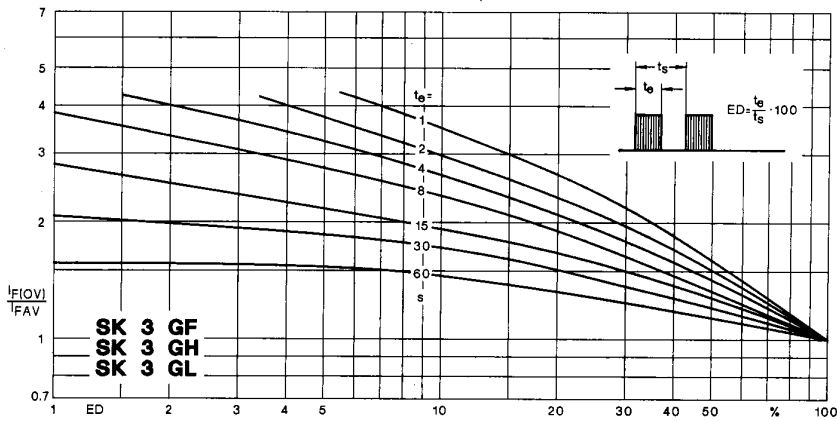
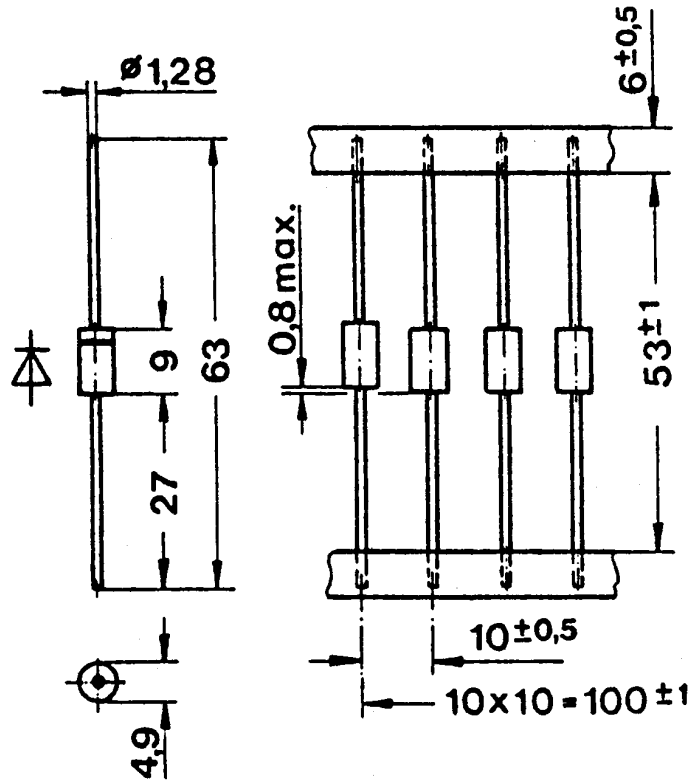

Fig. 10 Intermittent duty overload current

SK 3 GF/H/L

Case E 29

2000
diodes
per reel



Reel
dimensions
page B 9 - 2

Dimensions in mm