

cUL[®]us E220153

CQC CQC04001010234

ORDERING CODE 订购代码

HLS8- 22F - DC12V - C

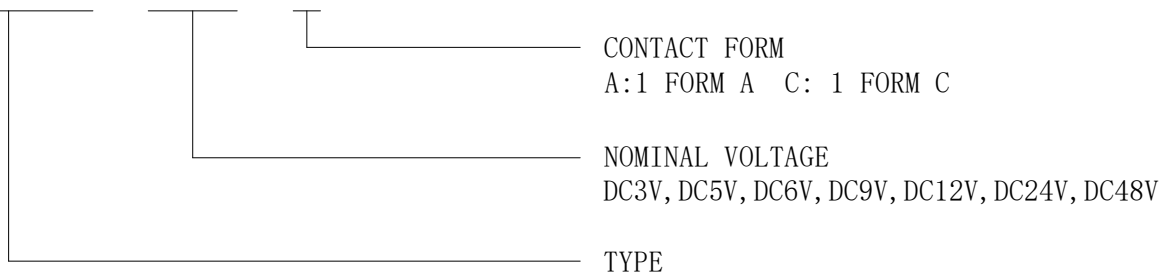

CONTACT DATA 触点参数：

Contact Form	触点形式	1A/1C
Contact Material	触点材料	Ag Alloy
Contact Ratings	触点负载	1A: 12A240VAC/15A120VAC 10A/28VDC 1C: 10A240VAC/12A120VAC 10A/28VDC
Max Switching Voltage	最大转换电压	250VAC/30VDC
Max Switching Current	最大转换电流	15A
Max Switching Power	最大转换功率	2400VA/240W
Initial Contact Resistance	接触电阻 (首次)	100mΩ Max at 6VDC 1A
Life Expectancy Electrical	电气寿命	100,000 Operations (rated load)
Life Expectancy Mechanical	机械寿命	10,000,000 Operations (no load)

GENERAL DATA 一般参数：

Insulation Resistance	绝缘阻值	100MΩ min at 500VDC	
Dielectric Strength Between Open Contacts	触点间耐压	750VAC 50-60HZ (1 minute)	
Dielectric Strength Between Contacts And Coil	触点与线圈间耐压	1500VAC 50-60HZ (1 minute)	
Operate Time	吸合时间	10ms max	
Release Time	释放时间	5ms max	
Ambient Temperature	环境温度	-40°C to +85°C	
Shock Resistance 冲击	Malfunction	动作极限	10G
	Destruction	破坏极限	100G
Vibration Resistance	振动	10-55Hz, 1.5mm double amplitude	
Ambient humidity	湿度	40-85% RH	
Weight	重量	Approx 13g	
Safety Standard	安全标准	UL CQC	

COIL DATA 线圈参数：(@20°C)

Rated Voltage 额定电压 (VDC)	Coil Resistance Ω (±10%) 线圈阻值		Max Operate Voltage 最大吸合电压 (VDC)	Min Release Voltage 最小释放电压 (VDC)	Max Applied Voltage 最大允许电压 (VDC)
	0.36W	0.51W			

3	25	-	2.25	0.15	3.9
5	70	-	3.75	0.25	6.5
6	100	-	4.5	0.3	7.8
9	225	-	6.75	0.45	11.7
12	400	-	9	0.6	15.6
24	1600	-	18	1.2	31.2
48	6400±15%	4500±15%	36	2.4	62.4

Outline Dimension 外形尺寸 (mm)

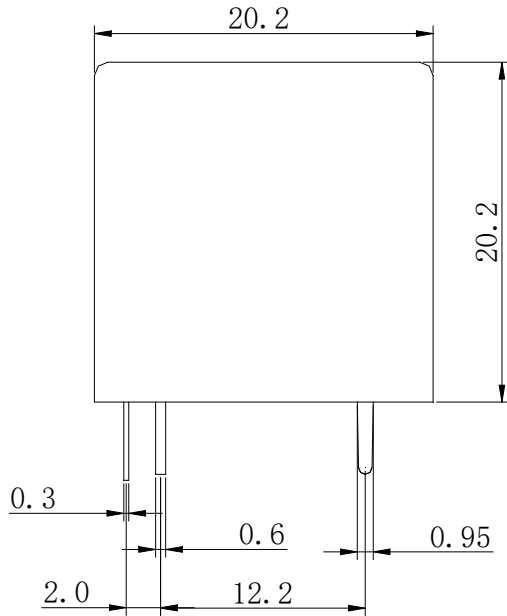

PC Board layout 安装图

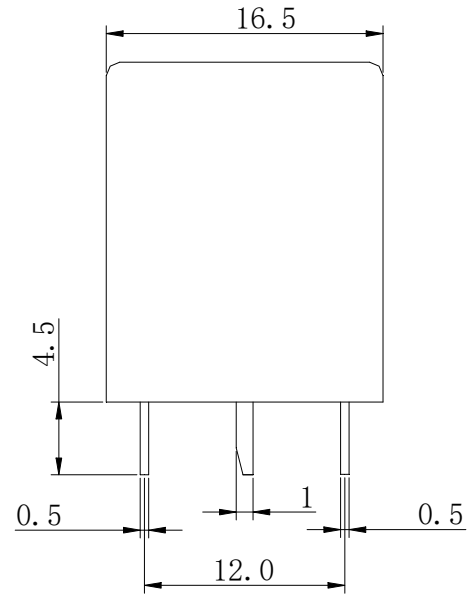

Wiring Diagram 接线图

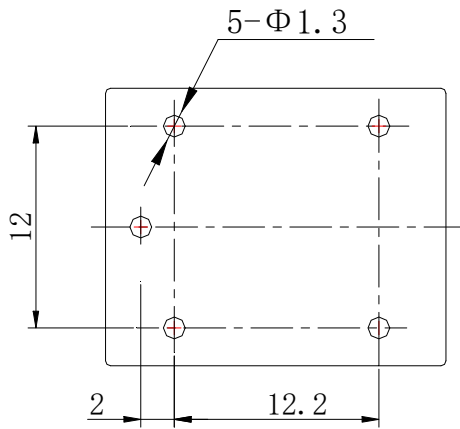

(Bottom View 底视)

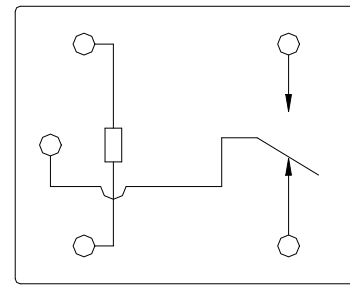

(Bottom View 底视)

声明：本产品规格书仅供客户使用时参考，若有更改，恕不另行通知。

对合力顺而言，不可能评定继电器在每个具体应用领域的所有性能参数要求，因而客户应该根据具体的使用条件选择与之相匹配的产品，若有疑问，请与合力顺联系获取更多技术支持。但产品选型责任仅由客户负责。

©宁波合力顺电子有限公司版权所有，本公司保留所有最终解释权。