



MUTUAL MOTOR

Mutual motor technology

产品规格承认书

客户(Customer): _____

送样日期(Sample Issue Date): _____

规格(Description): 92*92*25MM

版本(Edition): A

型号(Model No): M088AA2HB

客户承认栏 CONFIRMATION SIGNATURE	美途确认栏 MUTUAL SIGNATURE		
<p>本承认书内容若贵司确认无误, 请于上方承认栏内签章寄回。 Please confirm your acceptance of this approval sheet by return fax</p>	核准 APPD.	审核 EDAM.	制表 DRAW.

东莞市美途电机科技有限公司

DONGGUAN MUTUAL MOTOR TECHNOLOGY CO.,LTD

电话: 0769-82205666

传真: 0769-83720788

地址: 广东省东莞市横沥镇新城工业区兴业大道

Add : Metro Industrial Park,Industrial Avenue,Hengli Town,Dongguan City,Guangdong

www.mutualmotor.com

www.美途电机.com

产品规格承认书

**PRODUCT SPECIFICATION
APPROVAL SHEET**

一、 样品规格(Sample Specification):

项目 (Item)		规格/条件 (Specification/Condition)	
01	型号 Part No.	M088AA2HB	
02	外形尺寸 (Outline Dimension)	92mm*92mm*25mm	
03	额定电压 (Rated Voltage)	AC 110/220V	
04	电压范围 (Voltage Range)	AC 100V~130V/200V~240V	
05	频率 (Frequency)	60/50 Hz	
06	额定电流 (Rated Current)	0.12/0.06A±0.02	25°C 60~80%RH
07	消耗功率 (Power Consumption)	11/13W±10%	25°C 60~80%RH
08	转速 (Speed)	2800/2300RPM±10%	25°C 60~80%RH
09	最大风量 (Max. Air flow)	41/36CFM±10%	25°C 60~80%RH 額定電流 (Rated Current)
10	最大静压 (Max. Static Pressure)	0.16/0.14Inch-H2O	
11	噪音 (Noise Level)	35/33dB (A)	
12	重量 (Weight)	250g	

二、 电气规格(Electrical Specification):

项目 (Item)		规格/条件 (Specification/Condition)	
01	绝缘耐压 (Dielectric Strength)	1800V/0.5mA/3s	
02	绝缘阻抗 (Insulation Resistance)	阻抗保护 Impedance protected	
03	运转温升 (Temperature Test of Run)	$\Delta t < 70^{\circ}\text{C}$ 额定电压 (Rated Voltage)	
04	锁定检测 (Locked Rotor Protection)	$\Delta t < 130^{\circ}\text{C}$ 额定电压 (Rated Voltage)	

三、 环境条件(Environmental Specification):

项目 (Item)	规格/条件 (Specification/Condition)
-----------	---------------------------------

01	工作温/湿度范围(Operating Temp. Range)	温度(Temperature): -20°C~65°C 湿度(Humidity): 20%~85%RH
02	保存温/湿度范围(Storage Temperature)	温度(Temperature): -10°C~60°C 湿度(Humidity): 20%~95%RH
03	寿命(Life)	50000H

四、 主要材料/零件规格(Main Materials/Parts Specification):

项目(Item)		规格(Specification)
01	扇叶(Blade)	热塑性(PBT) PBT+15%GF
02	框架(Frame)	高质量铝合金外框防腐防湿结构(Aluminum ADC-12, Painted Black)
03	定子与转子(Stator& Rotor)	矽钢(Silicon steel)
04	漆包线(Magnet Wires)	Copper 2 UEW
05	绝缘套(Bobbin)	PA-66 UL 94 V-0

五、 商标说明(Label Marking):

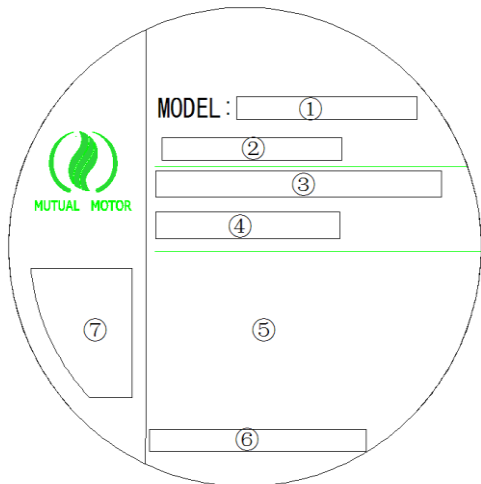

序号 (Ordinal)	说明 (Explain)
1	风扇型号 (Model)
2	轴承 类型 (Bearing Type)
3	电压 频率 (Voltage /Frequency)
4	功率 电流 (Current /Consumption)
5	接线方式(Connection mode)
6	生产地 (Producer)
7	安规 (Safety Approvals)

型号说明(Model Explain):

M088AA2HB

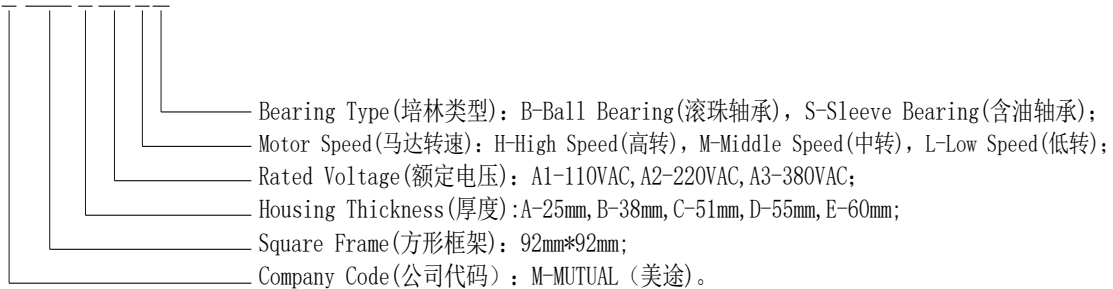

六、 外观尺寸图(Outline Dimension):

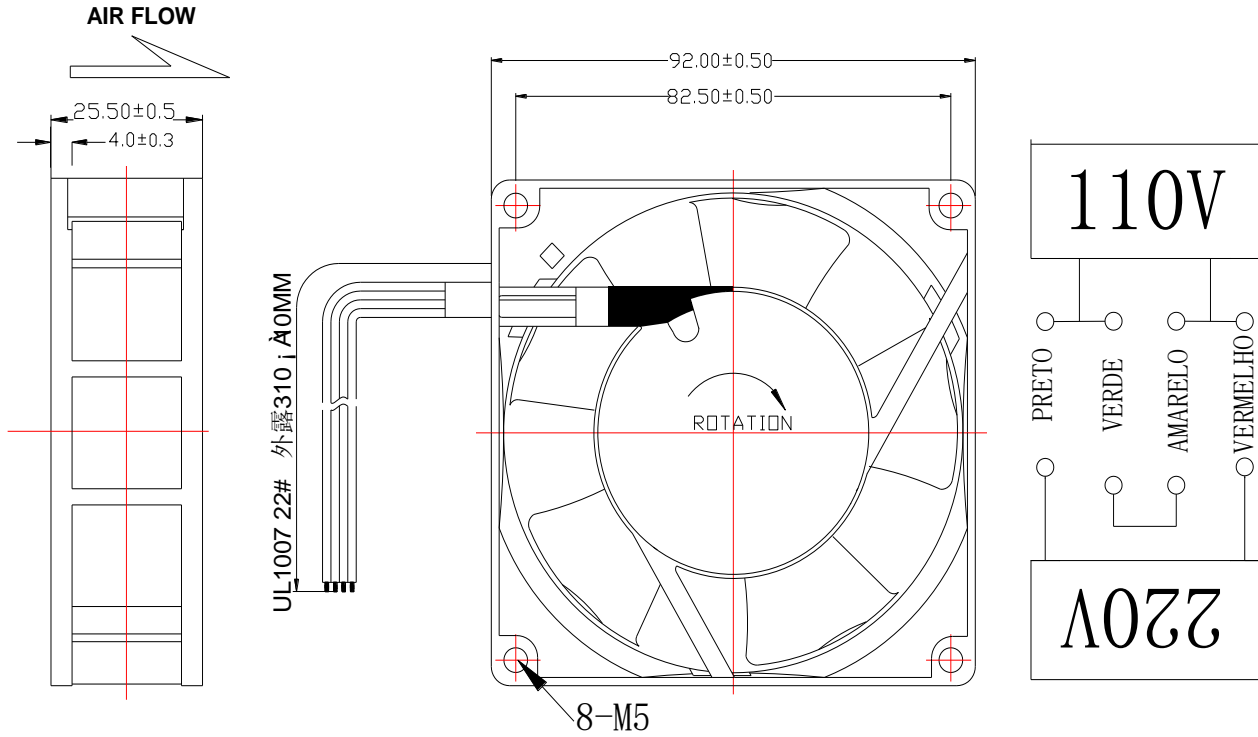

七、 特性图(Property):

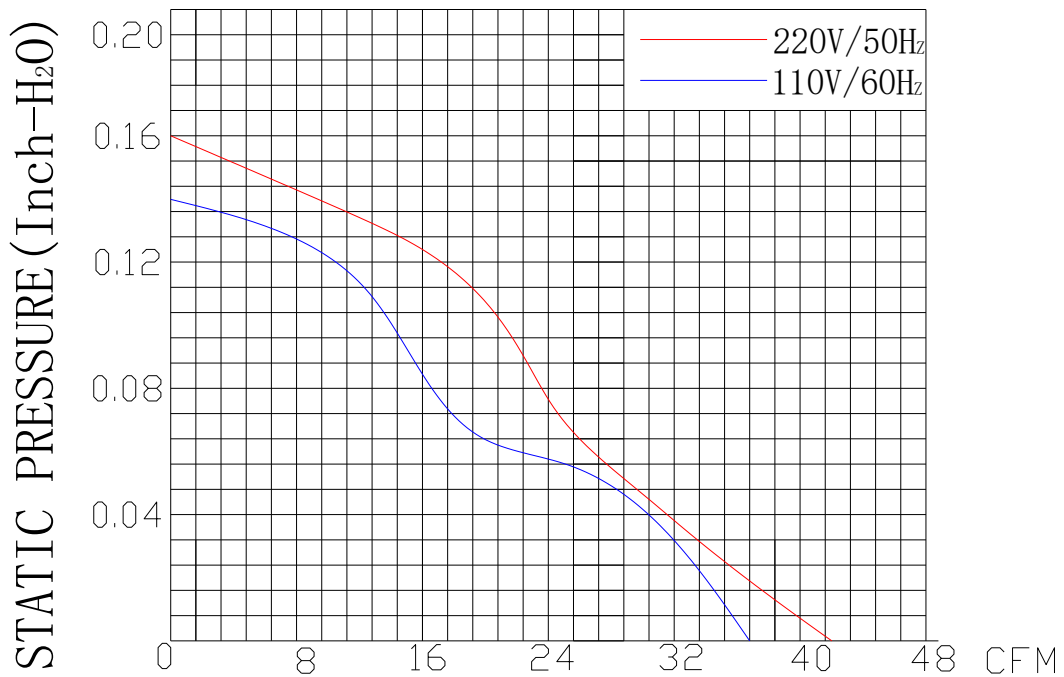

Above specification is only for reference and subject to change without notice.

以上数据仅供参考，如有变更恕不另行通知。