



# MUTUAL MOTOR

Mutual motor technology

## 产品规格承认书

客户(Customer): \_\_\_\_\_

送样日期(Sample Issue Date): \_\_\_\_\_

规格(Description): 172\*150\*51MM

版本(Edition): A

型号(Model No): M145CA2HB

客户承认栏 CONFIRMATION SIGNATURE	美途确认栏 MUTUAL SIGNATURE		
<div data-bbox="290 1276 719 1478" style="border: 1px solid black; padding: 5px; text-align: center;">本承认书内容若贵司确认无误, 请于上方承认栏内签章寄回. Please confirm your acceptance of this approval sheet by return fax.</div>	核准 APPD.	审核 EDAM.	制表 DRAW.

## 东莞市美途电机科技有限公司

DONGGUAN MUTUAL MOTOR TECHNOLOGY CO.,LTD

电话: 0769-82205666

传真: 0769-83720788

地址: 广东省东莞市横沥镇新城工业区兴业大道

Add : Metro Industrial Park,Industrial Avenue,Hengli Town,Dongguan City,Guangdong

## 产品规格承认书

PRODUCT SPECIFICATION  
APPROVAL SHEET

## 一、 样品规格(Sample Specification):

项目(Item)		规格/条件(Specification/Condition)	
01	型号 Part No.	M145CA2HB	
02	外形尺寸(Outline Dimension)	172mm*150mm*51mm	
03	额定电压(Rated Voltage)	AC 110V/220V	
04	电压范围(Voltage Range)	AC 100~130V/200~240V	
05	频率(Frequency)	60/50 Hz	
06	额定电流(Rated Current)	0.40A/0.24A±0.02A	25℃ 60~80%RH
07	消耗功率(Power Consumption)	29.0W/32.0W±10%	25℃ 60~80%RH
08	转速(Speed)	2850/2750RPM±10%	25℃ 60~80%RH
09	最大风量(Max. Air flow)	215/193CFM±10%	25℃ 60~80%RH 額定電流 (Rated Current)
10	最大静压(Max. Static Pressure)	0.59/0.55Inch-H2O	
11	噪音(Noise Level)	56/54 dB(A)	
12	重量(Weight)	920g	

## 二、 电气规格(Electrical Specification):

项目(Item)		规格/条件(Specification/Condition)	
01	绝缘耐压 (Dielectric Strength)	1800V/0.5Ma/3s	
02	绝缘阻抗 (Insulation Resistance)	阻抗保护 Impedance protected	
03	运转温升 (Temperature Test of Run)	t=<70℃ 额定电压(Rated Voltage)	
04	锁定检测 (Locked Rotor Protection)	t=<130℃ 额定电压(Rated Voltage)	

## 三、 安规情况(Safety Approvals):

安规 (Safety Approvals)	安规编号 (File No)	安规 (Safety Approvals)	安规编号 (File No)
UL	GPWV8. E343775	RoHS	68.160.10.00583.01
CUL	N/A	CCC	2013010401594874

TUV	E8N 101275910 002	CE	N810 12 75910 001
TUV-GS	N/A	C-Tick	N/A

#### 四、环境条件(Environmental Specification):

项目(Item)		规格/条件(Specification/Condition)
01	工作温/湿度范围(Operating Temp. Range)	温度(Temperature): -20°C-65°C 湿度(Humidity): 20%-85%RH
02	保存温/湿度范围(Storage Temperature)	温度(Temperature): -30°C-85°C 湿度(Humidity): 20%-95%RH
03	寿命(Life)	50000H

#### 五、主要材料/零件规格(Main Materials/Parts Specification):

项目(Item)		规格(Specification)
01	扇叶(Blade)	热塑性(PBT) PBT+15%GF
02	框架(Frame)	高质量铝合金外框防腐防湿结构(Aluminum ADC-12, Painted Black)
03	定子与转子(Stator& Rotor)	矽钢(Silicon steel)
04	漆包线(Magnet Wires)	Copper 2 UEW
05	绝缘套(Bobbin)	PA-66 UL 94 V-0

#### 六、商标说明(Label Marking):

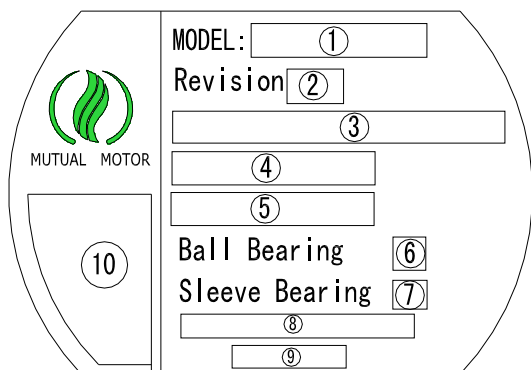

序号 (Ordinal)	说明 (Explain)
1	风扇型号 (Model)
2	版本 (Edition)
3	电压 频率 (Voltage /Frequency)
4	功率 电流 (Current /Consumption)
5	轴承 类型 (Bearing Type)
6	滚珠轴承 (Ball Bearing)
7	含油轴承 (Sleeve Bearing)
8	阻抗受保护 (Impedance protected)
9	生产地 (Producer)
10	安规 (Safety Approvals)

#### 型号说明(Model Explain):

M145CA2HB

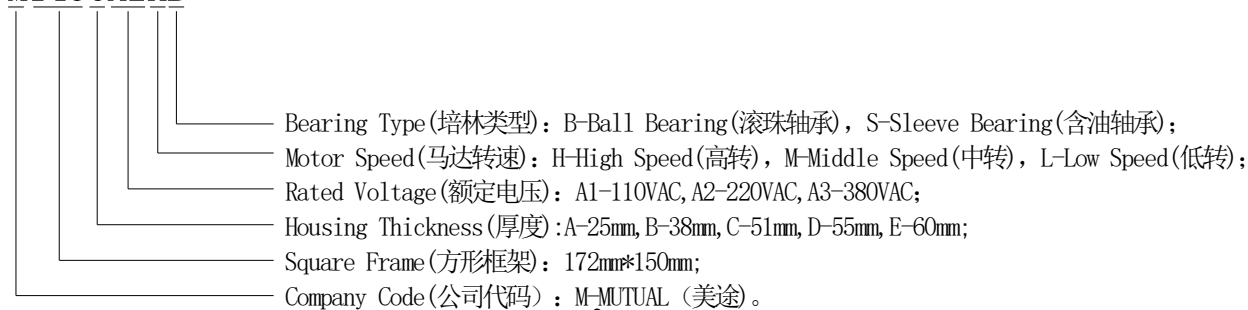

七、 外观尺寸图(Outline Dimension):

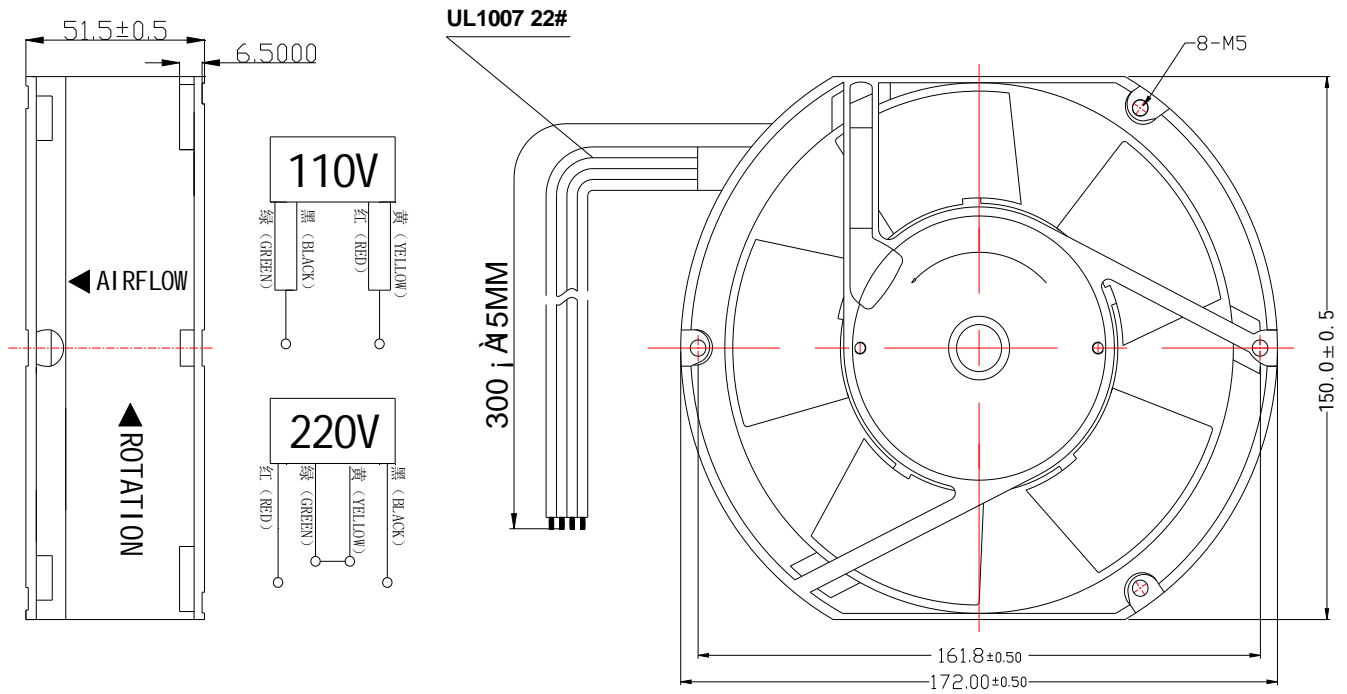

八、 特性图(Property):

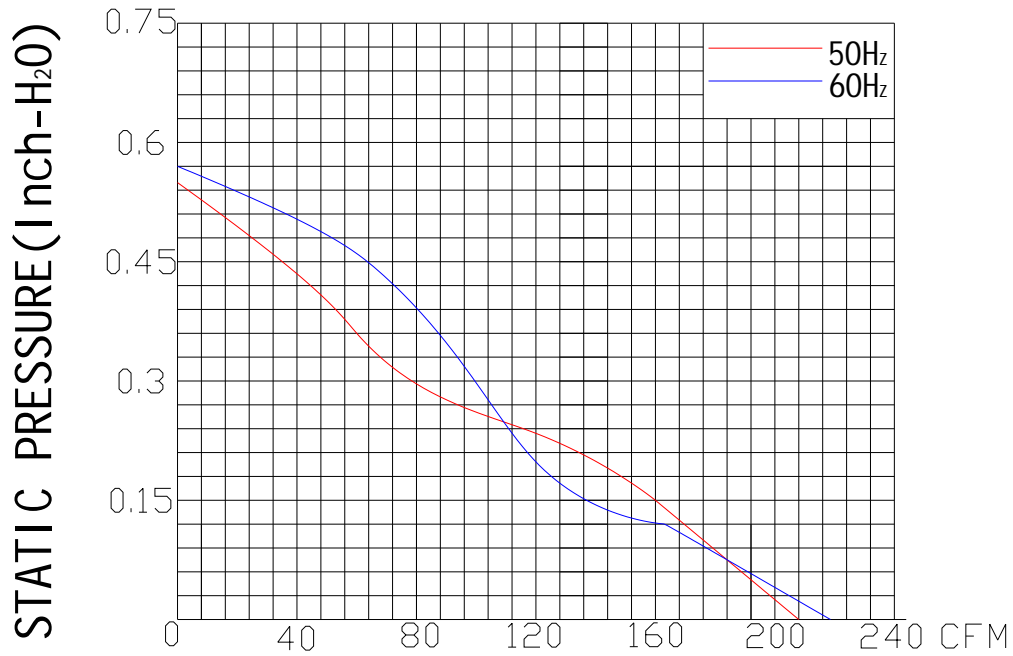

**Above specification is only for reference and subject to change without notice.**

以上数据仅供参考，如有变更恕不另行通知。