



**NINGBO FORYARD OPTO  
ELECTRONICS CO.,LTD.**

**WIRED RGB CONTROLLER**

**PartNO.:FY-V300-DC12V**

# **Wired RGB Controller**

**Model: FY-V300-DC12V**





**Product Instruction**

**FY-V300 key-press type** multifunctional LED RGB controller is used exclusively to control the RGB color of the LED modules with 4 lines and 3 loops (common anode) to change entirely and synchronously.

**🕒 Performance Specification:**

<b>Model:</b>	<b>FY-V300-DC12V</b>		
<b>Working Voltage:</b>	<b>12V DC</b>	<b>Output Load Current:</b>	<b>9 A/loop×3</b>
<b>Self Power Consumption:</b>	<b>&lt; 1W</b>	<b>Output Power:</b>	<b>1~ 300 W</b>
<b>Speed Level:</b>	<b>8 Levels</b>	<b>Brightness Level:</b>	<b>0~8 Level</b>
<b>Case Dimension:</b>	<b>L211×W40×H30 MM</b>	<b>Working Temperature:</b>	<b>-10℃ ~ 50℃</b>
<b>Packing Size:</b>	<b>L218×W45×H36 MM</b>	<b>Weight:</b>	<b>160g</b>
<b>Interface Type:</b>	<b>Terminal Interface</b>	<b>Protective Function:</b>	<b>Short circuit Self-protection</b>
<b>Features:</b>	<b>Small and exquisite shape, simple operations, various controlling effect, great capacity in load, little power consumption and auto mode save.</b>		
<b>Applicable LED Module:</b>	<b>All the RBG LED modules and strips manufactured by our company.</b>		

**🕒 Operation Instruction:**

1. "Mode" key is used to choose a mode. The mode will be changed after each press and total 10 modes can be chosen circularly.
2. "PAUSE" key is used to pause. When it is working in order, press "PAUSE" key, the present color or gray scale will stand by. Press "PAUSE" again or other key, it will be back to the normal state.
3. "SPD+" or "SPD-" key is to change the speed. There are total 8 levels of speeds adjustable.

The default speed when the controller powered is the 1<sup>st</sup> level speed, namely the maximum speed.

---



4. "BRI+" or "BRI-" key is to change the brightness. There are total 8 levels of brightness adjustable. The default brightness when the controller powered is the maximum.
5. After above settings done, the controller will automatically save the settings. Then when powering the controller next time, it will work under the final mode settings saved last time.

**\*\*Precaution: When operating, please press the keys gently, but don't overexert to avoid the membrane key-presses failing to function.**

**◆ List for lighting effects:**

<b>Mode</b>	<b>Lighting Effects</b>	<b>Remark</b>
1	<b>RG Jumping</b>	
2	<b>GB Jumping</b>	
3	<b>RB Jumping</b>	
4	<b>Seven-color Jumping</b>	
5	<b>RG Fading</b>	
6	<b>GB Fading</b>	
7	<b>BR Fading</b>	
8	<b>RGB Fading</b>	
9	<b>Seven-color Gradual Brighter or Dimmer</b>	
10	<b>Auto Cycle Mode</b>	<b>Automatically cycle from the 1<sup>st</sup> to 9<sup>th</sup> mode.</b>



**◆ Connection for Reference:**

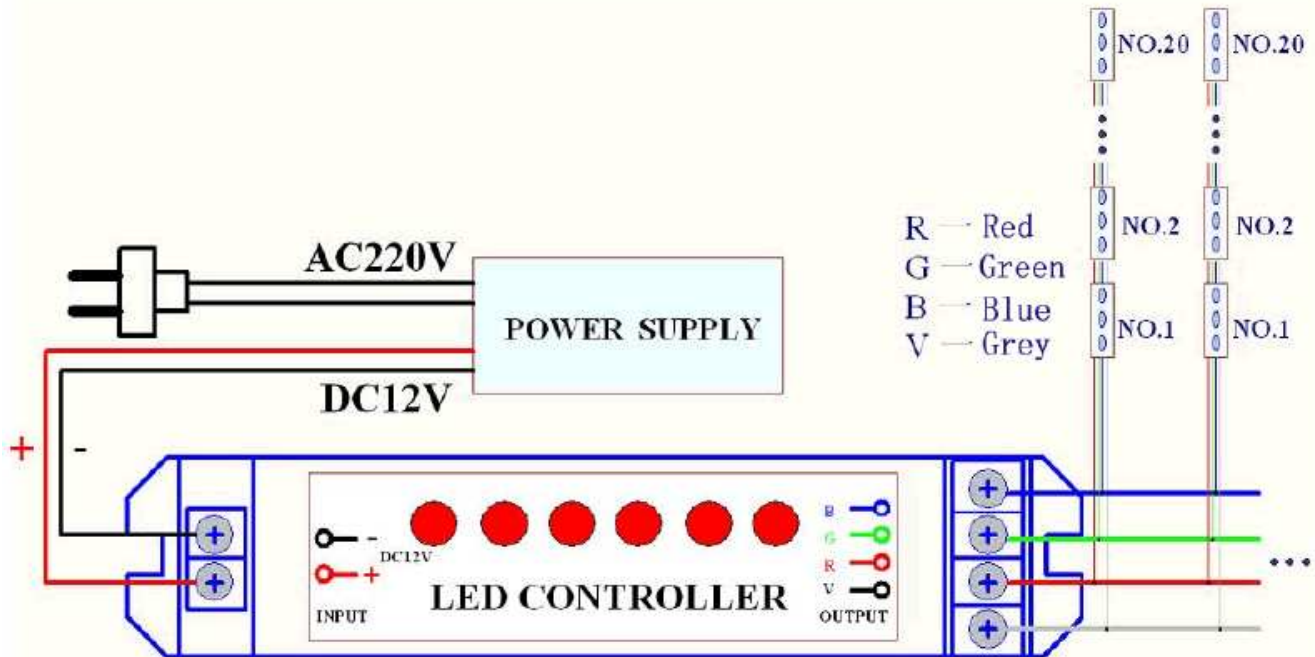

**◆ Problem Analysis and Solution:**

Problem	Reason Analysis	Solution
LED out of work	The wire on the wire terminal in bad connection	Re-connect the wires.
	Anode grey wire in the wrong connection	
	The positive and negative wires of the power supply in short circuit	Re-power
	Be interfered	
In wrong color	The wire is not corresponding with the LED	Re-connect the wire to the corresponding LED.



**◆ Installation:**

1. The distance between controller and power supply or between LED modules and controller should be no more than 3 meters;
  2. When choosing the power cord, please remember that the total current of the LED modules connected with the power cord should not exceed the normal working current of the power cord;
  3. Please make sure that the metal case of the power supply is connected with the ground line since the power supply must be grounding;
  4. The waterproof and insulating treatment should be done for the last module of each loop;
  5. The controller and power supply must work in the ventilated and dry environment;
  6. The Grey output wire(V) of the controller should be connected with the grey common anode wire(DC12V) of the controlled modules, while another three output wires of red, green and blue should be connected with the red, green and blue wires of the controlled modules;
  7. Please confirm that no short circuit exists between input or output wires of the main line of the controlling. If electrified when short circuit existing, the internal components may be burned out;
  8. When doing the connection and installation, please take care and don't disassemble or install without switching off the power;
  9. If the controller working out of the way, please don't disassemble or removing privately, but contact with the manufacturer to solve the problems.
-