

MG-3060

Digital Insulation Resistance Tester

OPERATION MANUAL



Contents

Safety Rules	2
Performance Features	3
Specification	4
Operation Schematic View	5
Operation Instruction	6
Maintenance	9
Accessories	9



Warning

This user manual includes warning and safety specifications, which shall be strictly followed to ensure safety. Please be sure to read through this user manual before using this instrument.

I. General Introduction

The brand new MG-3060 instrument can measure insulation resistance, AC voltage.

As a new generation all mighty electrical test instrument we have successfully developed recently , it has made fundamental changes to the circuit industry of conventional insulation resistance . Aided by the nice and fashionable design, MG-3060 have more and stronger functions , are easier to use and more reliable . The instrument and accessories are all in the toolbox , fit for field application . It can be used to test the insulation resistance of power system , electrical equipment , lightning arrester equipment , and measure AC voltage and phase sequence test .

II Safety Rules

1. Be sure to read this user manual carefully before using this instrument.
2. This meter is designed in accordance with IEC publication 1010, (over voltage category) CAT III-1000V.
3. Be sure to check the insulation layer of the probe is sound and free of any damage before using this instrument.
4. To prevent electrical shock, be sure not to touch electric lead and circuit when the test is in process.
5. Be sure to confirm the range selection switch has been set in the appropriate range before testing.
6. Confirm the plug of the wire has been tightly inserted in the terminal.
7. Be sure not to use the instrument when it is moist
8. Be sure not to turn the function selection switch when the test is in process.
9. Do not apply any voltage higher than 600V, AC or DC between test terminals.

10. Do not test in inflammable environment since spark may lead to explosion.
11. Stop using the instrument in case any metal is exposed because the shell or test wire is broken when the test is in process.
12. Be sure that the test wire has been removed from the test terminal and the function range selection switch is in the OFF position when you remove the rear cover to replace battery.
13. Do not replace battery when the instrument is moist.
14. Be sure to put the function range selection switch at the OFF position when your work is over.
15. Remember to remove the battery when you are going to not use the instrument for a long period of time.
16. When the instrument displays “”, replace battery promptly, to ensure the accuracy of measurement.

III. Performance Features

1. Low power consuming CMOS dual integral A/D conversion IC, automatic zero
2. LCD: 3 1/2 bit large screen display, maximum reading 1999
3. Data holding function, functional icons display
4. Can measure voltage lower than AC600V
5. Low Battery indication
6. LCD backlight function
7. Can test phase sequence
8. Automatically convert range (Insulation test only)
9. Perfect protection circuits, which can effectively prevent the harm of reverse voltage
10. LCD dimension: (65x48)mm (digit is 29mm high)
11. Power: 8x1.5V (R6 AA) battery

- 12. Dimension: 190x155x75mm
- 13. Weight: approximately 900g(including batteries)
- 14. The instrument and accessories can be put into one for easy carriage
- 15. Environment conditions
- 16. Operating temperature: 0C~40C
Relative humidity<80%
Storage temperature: -10C~50C
Relative humidity<80%

IV. Specification

Accuracy: (%reading+digit) the warranty is one year
Environment temperature: 23 °C±5°C
Relative humidity: <75%

1. Insulation Resistance

Model	MG-3060			
Testing Voltage	500/ 1000 / 2500V			
OutVoltage	90%-110% ofthe test voltage			
Range	0.1MΩ-20 GΩ			
Resolution	0.01MΩ			
Accuracy	0.1MΩ-200MΩ ± (3%rdg+5dgt)			
	200MΩ —10GΩ± (5%rdg+5dgt)			
	10GΩ—20GΩ ± (10%rdg+5dgt)			

2. AC Voltage Measurement

Measurement range: 0-600V

Accuracy: (2% rdg+5dgt)

Resolution: 1V

Test frequency: 50/60Hz

3. Phase Sequence Test

Phase-phase voltage range tested: 100V-450V

Frequency tested: 40-60Hz

4. Phase Sequence test result is indicated by LED No and display in LCD

V. Operation Schematic View

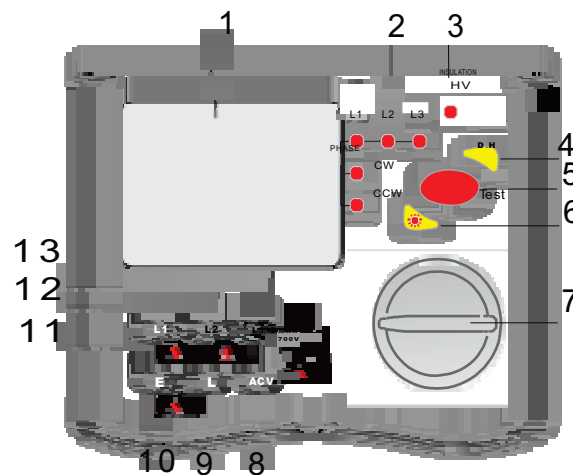

1. LCD display
2. Phase sequence measurement LED indicators (CW, CCW, L1, L2 and L3)
3. Insulation resistance measurement high voltage LED indicator
4. Data holding switch
5. Test button
6. Backlight indicator switch
7. Function switch
8. ACV Input terminal
9. LINE input terminal (Insulation)
10. EARTH input terminal (Insulation)
11. Phase sequence L 1 input terminal
12. Phase sequence L2 input terminal
13. Phase sequence L3/ACV measurement G terminal/ shield input terminal for insulation

VI. Operation Instruction

1. Safety Precautions

- ① Be careful of the high voltage shock. When the insulation resistance test is over, be sure to confirm the high voltage on the object under test has been discharged.
- ② Do not touch the object under test when the test is in process in case you should get electrical shock.
- ③ The object under test shall not be live and be sure to confirm the object under test is securely earthed when you test the insulation resistance . Short circuit the two test terminals of the object under test to discharge before you start the test .
- ④ Do not include any external voltage into the test loop when you test the insulation resistance.
- ⑤ Be sure to confirm the knob switch is in right position and the test wire is firmly connected before you start the test.
- ⑥ When the high voltage switch has been turned on, up to 5000V high voltage is generated between L terminal and E terminal . Be sure not to touch any exposed part of instrument and the object under test, otherwise you may get electrical hazard.

2. AC Voltage Test

- ① Do not test any voltage higher than 600V.
- ② Connection of Test Terminals.
Insert the red test lead into the ACV socket of the instrument and the black test lead into the G socket of the instrument.
- ③ Set the rotary switch at the “ 600V” position and connect the probe to the object under test.
- ④ The value displayed by the instrument now is the AC voltage between two terminals of the object under test .

3. Test of Insulation Resistance.

① Connection of Test Terminals

Insert the red test lead into the L socket of the instrument and the plug of the black test lead with flat crocodile clamp into the E socket of the instrument .

② Test connection

The wiring of E socket of the instrument is the earth wire ;
The wiring of L socket of the instrument is the line wire.
The G terminal socket of the instrument is the shield wire to test the high insulation resistance. If necessary, insert the plug of the black test wire with probe into the G terminal socket of the instrument, to eliminate the measurement error caused by the leak current in the surface of the product, and ensure the accuracy of the test ;

③ Selection of Rated Voltage

Select the rated voltage you need to test the insulation resistance by turning the knob to the relevant voltage class.

④ Test Operation

Connect the other terminal of the wire to the object under test . Press the Test / Stop key , the red indicator turns on , indicating the high voltage output of test is connected.

When the test has started, the LCD of the instrument displays some readings. The value displayed by LCD is the insulation resistance of the object under test.

When the high voltage indicator is on, it indicates the test instrument is working properly.

⑤ Turn off

When the test is over , press the Test / Stop key , the red indicator turns off , indicating the test high voltage has been disconnected . Put the DIP switch at OFF position, LCD displays nothing. For capacitive load, be sure to discharge the residual charges in the

object under test before you remove the test wire , to prevent the residual charges discharge and harm people .

4. Phase Sequence Measurement Method

There is high voltage in the 3-phase wire . It would be highly dangerous to touch, therefore be sure to handle with care when you connect wires for a 3-phase measurement. In case the instrument indicator is not on when the test wire has been connected, one phase may be live. Be careful not to get shocked. Do not test any voltage that is higher than the rated voltage of 100V/450V/ 40-60Hz (3- phase AC) . Do not measure for more than 30 minutes when the voltage is higher than 200V and not more than 3 minutes when the voltage is higher than 450V. The duration mentioned above commences from the moment the probe wires of two phase sequences are connected.

① The phase sequence function allows you to test the phase sequence of 3-phase AC power supply (100V-450V/40-60Hz). When you have connected the phase sequence probes with the test wires by input terminals , you can judge the positive phase and reverse phase of 3-phase AC according to LED indicator and beep, and phase missing indicated by LED .

② Test State

Phase Sequence Test Indication	Open Phase Test Indication	Beep
Positive phase (CW indicator is on)	L1, L2 and L3 indicators are on.	Long beep
Reverse phase (CCW indicator is on)	L1, L2 and L3 indicators are on.	No beep
Missing phase (CCW indicator is on)	Any of L1, L2 and L3 is not on	No beep

Note: When the measurement probes have been connected, the phase sequence measurement function shall indicate the positive phases and reverse phases of a 3-phase AC, and the LED indicator will indicate the phase missing. Be sure to measure with 3 triple-color test wires with 3 round crocodile clamps .

VII. Maintenance

This instrument is a precision electronic instrument, be sure to maintain it well.

1. Do not apply the instrument to any AC voltage higher than 600V.
2. Do not use the instrument when the rear cover of the instrument is in place.
3. To replace battery, remove the probe and power off the instrument first. Unscrew the screws of the battery cover and remove the battery cover. Be sure to replace the battery according to the specification requirement.
4. Do not forget to remove the battery if you are not going to use the instrument for a long period of time. Place the instrument at a dry and well ventilated environment.
5. Do not alter any internal circuit of this instrument at will in case it is damaged.

VIII. Accessories

1. One copy of user manual
2. 1 toolbox
3. 2 sets of dedicated test wires (a phase sequence test wire, an insulation resistance test wire)
4. 8 cells of 1.5V AA batteries

