



MUTUAL MOTOR

Mutual motor technology

产品规格承认书

客户(Customer): _____

送样日期(Sample Issue Date): _____

规格(Description): 80*80*38mm

版本(Edition): A

型号(Model No): M075BA2HS

客户承认栏 CONFIRMATION SIGNATURE	美途确认栏 MUTUAL SIGNATURE		
<div data-bbox="280 1291 708 1470" style="border: 1px solid black; padding: 5px;"><p>本承认书内容若贵司确认无误, 请于上方承认栏内签章寄回. Please confirm your acceptance of this approval sheet by return fax.</p></div>	核准 APPD.	审核 EDAM.	制表 DRAW.

东莞市美途电机科技有限公司

DONGGUAN MUTUAL MOTOR TECHNOLOGY CO., LTD

电话: 0769-82205666

传真: 0769-83720788

地址: 广东省东莞市横沥镇新城工业区兴业大道

Add : Metro Industrial Park, Industrial Avenue, Hengli Town, Dongguan City, Guangdong

www.mutualmotor.com

www.美途电机.com

产品规格承认书

PRODUCT SPECIFICATION APPROVAL SHEET

一、 样品规格(Sample Specification):

项目(Item)		规格/条件(Specification/Condition)	
01	型号 Part No.	M075BA2HS	
02	外形尺寸(Outline Dimension)	80mm*80mm*38mm	
03	额定电压(Rated Voltage)	AC 110/220V	
04	电压范围(Voltage Range)	AC 100V~130V/200V~240V	
05	频率(Frequency)	60/50Hz	
06	额定电流(Rated Current)	0.10/0.06A±10%	25℃ 60~80%RH
07	消耗功率(Power Consumption)	7/10W±10%	25℃ 60~80%RH
08	转速(Speed)	3050/2550RPM±10%	25℃ 60~80%RH
09	最大风量(Max. Air flow)	41/35CFM±10%	25℃ 60~80%RH 額定電流 (Rated Current)
10	最大静压(Max. Static Pressure)	0.21/0.16Inch-H2O	
11	噪音(Noise Level)	36/33dB(A)	
12	重量(Weight)	310g	

二、 电气规格(Electrical Specification):

项目(Item)		规格/条件(Specification/Condition)	
01	绝缘耐压 (Dielectric Strength)	1800V/0.5mA/3s	
02	绝缘阻抗 (Insulation Resistance)	阻抗保护 Impedance protected	
03	运转温升 (Temperature Test of Run)	△t=<70℃ 额定电压(Rated Voltage)	
04	锁定检测 (Locked Rotor Protection)	△t=<130℃ 额定电压(Rated Voltage)	

三、 安规情况(Safety Approvals):

安规 (Safety Approvals)	安规编号 (File No)	安规 (Safety Approvals)	安规编号 (File No)
UL	N/A	RoHS-TUV	68.160.10.00583.01
CUL	N/A	CCC	2013010401594874
TUV	E8N 101275910 002	CE	N810 12 75910 001
TUV-GS	N/A	C-Tick	N/A

四、环境条件(Environmental Specification):

项目(Item)		规格/条件(Specification/Condition)
01	工作温/湿度范围(Operating Temp. Range)	温度(Temperature): -20℃~65℃ 湿度(Humidity): 20%~85%RH
02	保存温/湿度范围(Storage Temperature)	温度(Temperature): -30℃~85℃ 湿度(Humidity): 20%~95%RH
03	寿命(Life)	50000H

五、主要材料/零件规格(Main Materials/Parts Specification):

项目(Item)	规格(Specification)
01 扇叶(Blade)	热塑性(PBT) PBT+15%GF
02 框架(Frame)	高质量铝合金外框防腐防湿结构(Aluminum ADC-12, Painted Black)
03 定子与转子(Stator& Rotor)	矽钢(Silicon steel)
04 漆包线(Magnet Wires)	Copper 2 UEW
05 绝缘套(Bobbin)	PA-66 UL 94 V-0

六、商标说明(Label Marking):

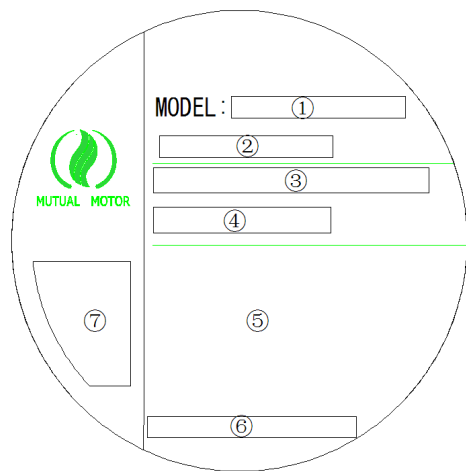

序号 (Ordinal)	说明 (Explain)
1	风扇型号 (Model)
2	轴承 类型 (Bearing Type)
3	电压 频率 (Voltage /Frequency)
4	功率 电流 (Current /Consumption)
5	接线方式 (Connection mode)
6	生产地 (Producer)
7	安规 (Safety Approvals)

型号说明(Model Explain):

M075BA2HB

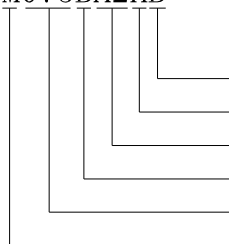

- Bearing Type (轴承类型): B-Ball Bearing (滚珠轴承), S-Sleeve Bearing (含油轴承);
- Motor Speed (马达转速): H-High Speed (高转), M-Middle Speed (中速), L-Low Speed (低速);
- Rated Voltage (额定电压): A1-120VAC, A2-220VAC, A3-380VAC;
- Housing Thickness (厚度): A-25mm, B-38mm, C-51mm, D-55mm, E-60mm;
- Square Frame (方形框架): 80mm*80mm;
- Company Code (公司代码): M-MUTUAL (美途)。

七、 外观尺寸图(Outline Dimension):

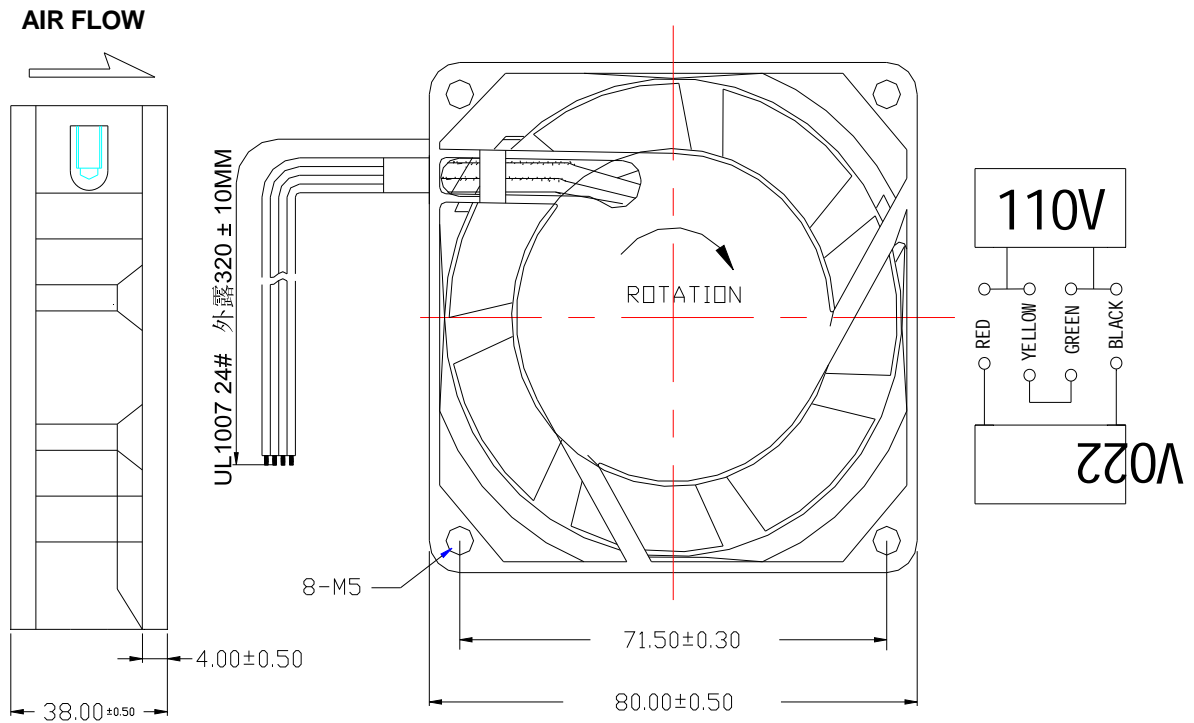

八、 特性图(Property):

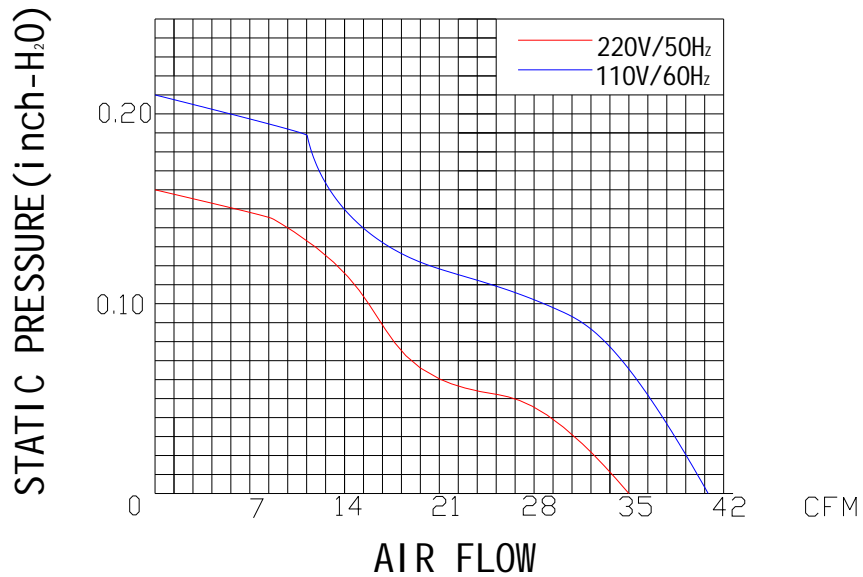

Above specification is only for reference and subject to change without notice.

以上数据仅供参考，如有变更恕不另行通知。