

# Autonics Threaded/Side Mounting Photoelectric Sensor BH SERIES INSTRUCTION MANUAL

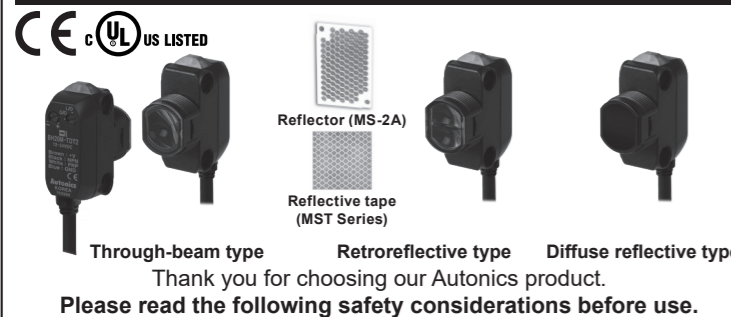

## ■ Safety Considerations

- ⚠ Please observe all safety considerations for safe and proper product operation to avoid hazards.
- ⚠ symbol represents caution due to special circumstances in which hazards may occur.
- Warning** Failure to follow these instructions may result in serious injury or death.
- Caution** Failure to follow these instructions may result in personal injury or product damage.
- Warning**
  - Fail-safe device must be installed when using the unit with machinery that may cause serious injury or substantial economic loss. (e.g. nuclear power control, medical equipment, ships, vehicles, railways, aircraft, combustion apparatus, safety equipment, crime/disaster prevention devices, etc.)
  - Do not use the unit in the place where flammable/explosive/corrosive gas, high humidity, direct sunlight, radiant heat, vibration, impact, or salinity may be present.
  - Do not disassemble or modify the unit.
  - Do not connect, repair, or inspect the unit while connected to a power source.
  - Check 'Connections' before wiring.

## ⚠ Caution

- Use the unit within the rated specifications.
- Use dry cloth to clean the unit, and do not use water or organic solvent.

## ■ Dimensions

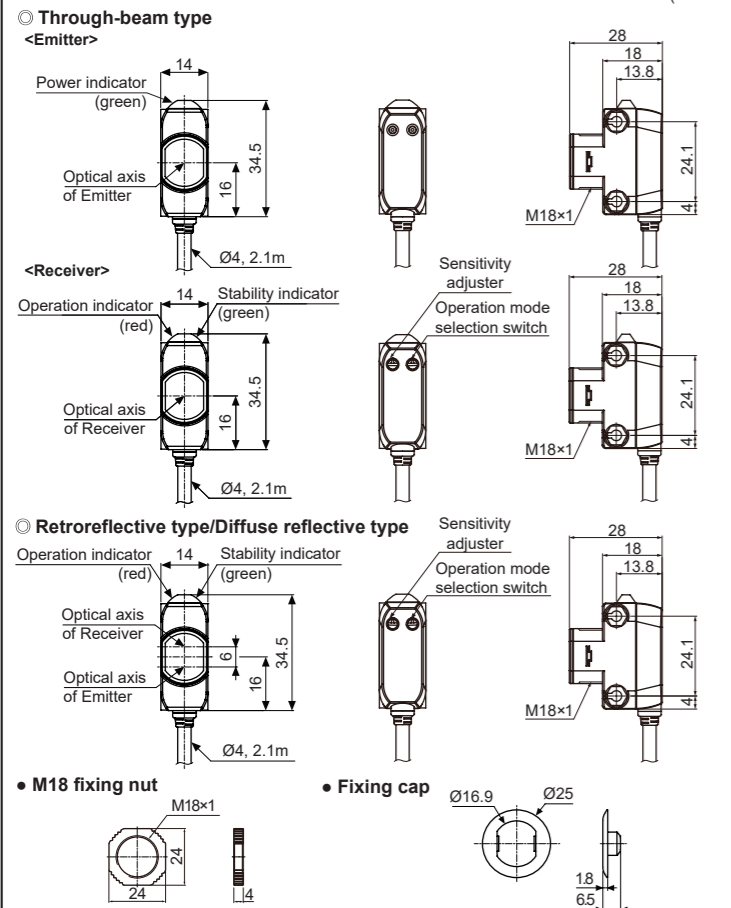

⚠ The above specifications are subject to change and some models may be discontinued without notice.  
 ⚠ Be sure to follow cautions written in the instruction manual and the technical descriptions (catalog, homepage).

## ■ Model

Model	Sensing distance	Sensing type	Power supply	Output
BH20M-TDT	20m	Through-beam type	12-24VDC	Transistor output (NPN/PNP)
BH4M-PDT	4m	Retroreflective type (built-in polarized filter)		
BH1M-DDT	1m	Diffuse reflective type		
BH300-DDT	300mm			

## ■ Specifications

Model	BH20M-TDT	BH4M-PDT	BH1M-DDT	BH300-DDT
Sensing type	Through-beam	Retroreflective (built-in polarized filter)	Diffuse reflective	
Sensing distance	20m	4m <sup>※1</sup>	1m <sup>※2</sup>	300mm <sup>※3</sup>
Sensing target	Opaque material over Ø20mm	Opaque material over Ø75mm	—	
Hysteresis	Max. 20% at sensing distance			
Response time	Max. 1ms			
Power supply	12-24VDC ±10% (ripple P-P: max. 10%)			
Current consumption	Emitter/Receiver : max. 20mA	Max. 30mA	Max. 35mA	Max. 30mA
Light source	Red LED (660nm)	Red LED (660nm)	Infrared LED (850nm)	Red LED (660nm)
Sensitivity adjustment	Sensitivity adjuster			
Operation mode	Light ON / Dark ON selectable by switch			
Control output	NPN / PNP open collector simultaneous 2 output · Load voltage: max. 26.4VDC-      · Load current: max. 100mA · Residual voltage - NPN: max. 1VDC-, PNP: max. 2.5VDC			
Protection circuit	Interference prevention function (except through-beam type), Power reverse polarity protection circuit, Output short over current protection circuit			
Indicator	Operation indicator: red LED, Stability indicator: green LED (emitter of through-beam type's power indicator: green)			
Connection	Cable type			
Insulation resistance	Over 20MΩ (at 500VDC megger)			
Dielectric strength	1,000VAC 50/60Hz for 1 minute			
Vibration	1.5mm amplitude at frequency of 10 to 55Hz (for 1 min) in each X, Y, Z direction for 2 hours			
Shock	500m/s <sup>2</sup> (approx. 50G) in X, Y, Z direction for 3 times			
Environment	Sunlight: max. 11,000lx, Incandescent lamp: max. 3,000lx (receiver illumination) Ambient temp. <sup>※4</sup> -25 to 55°C, storage: -40 to 70°C Ambient humi. <sup>※5</sup> 35 to 85%RH, storage: 35 to 85%RH			
Protection structure	IP67 (IEC standard)			
Material	Case: polycarbonates, LED indicator: polycarbonates, sensing part: polymethyl methacrylate acrylic			
Cable	Ø4mm, 4-wire, 2.1m (emitter of through-beam type: Ø4mm, 2-wire, 2.1m) (AWG24, core diameter: 0.08mm, number of cores: 40, insulator out diameter: Ø1.03mm)			
Accessories	Common	Adjustment screwdriver, fixing bracket, M18 fixing nut: 1, fixing cap: 1, M3 bolt: 2, M3 nut: 2		
Approval	Individual	Reflector (MS-2A)	—	
Weight <sup>※5</sup>	Approx. 190g (approx. 120g)	Approx. 140g (approx. 60g)	Approx. 130g (approx. 60g)	

- ※1: The sensing distance is specified with using the MS-2A reflector. The distance between the sensor and the reflector should be set over 0.1m. When using reflective tapes, the reflectivity will vary by the size of the tape. Please refer to the catalog or web site.
- ※2: Non-glossy white paper 300×300mm.
- ※3: Non-glossy white paper 100×100mm.
- ※4: UL approved surrounding air temperature 40°C
- ※5: The weight includes packaging. The weight in parenthesis is for unit only.
- ※The temperature or humidity mentioned in Environment indicates a non freezing or condensation.

## ■ Control Output Diagram

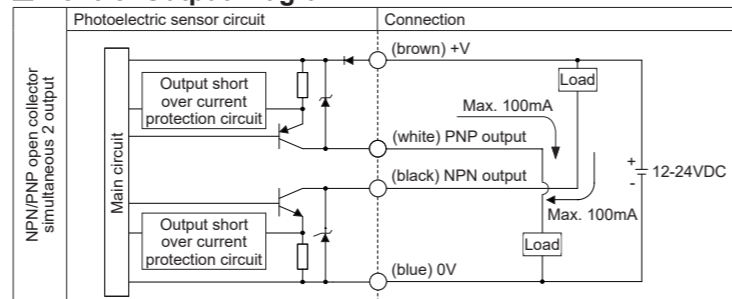

⚠ If short-circuit the control output terminal or supply current over the rated specification, normal control signal is not output due to the output short over current protection circuit.

## • Bracket

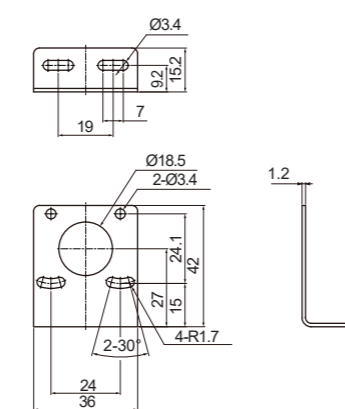

## • Reflector (MS-2A)

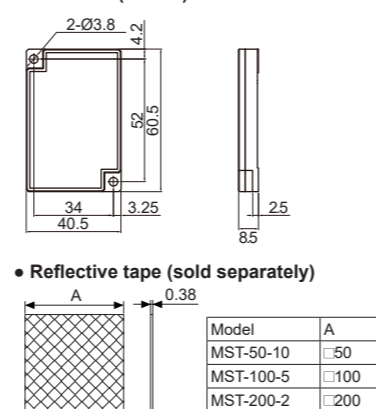

## ■ Connections

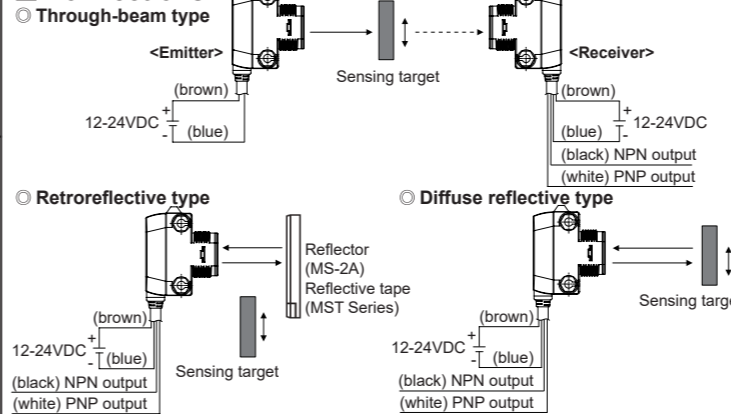

## ■ Installation and Sensitivity Adjustment

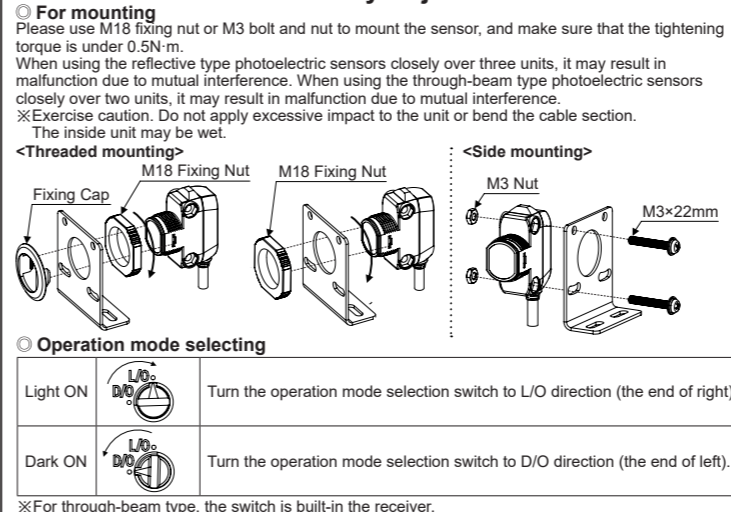

⚠ For through-beam type, the switch is built-in the receiver.

## • Optical axis adjustment

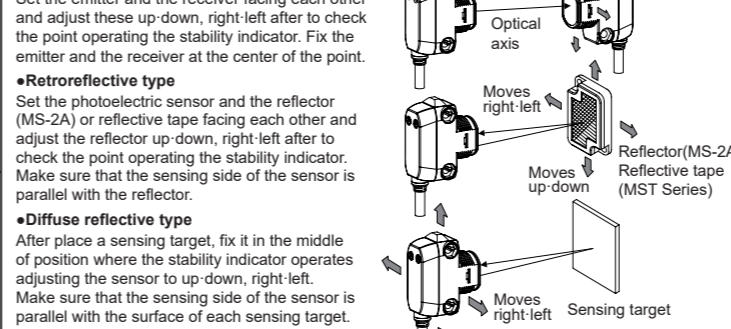

## • Sensitivity adjustment

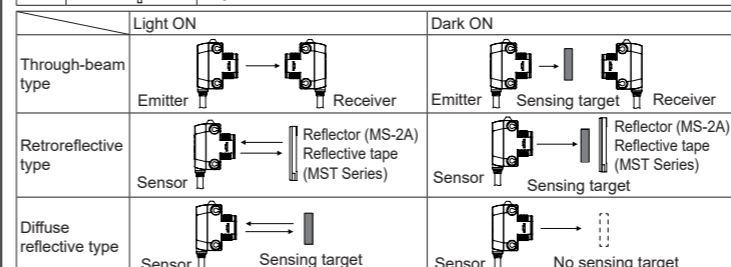
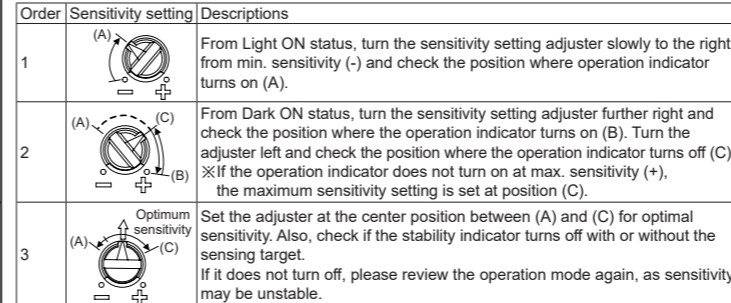

⚠ Please set the sensitivity setting adjuster is executed in stable Light ON area and the reliability of environment (temperature, supply, dust etc.) is increased after the mounting it in a stable area.  
 ⚠ It may cause breakdown when the sensitivity setting adjuster or the operation mode selection switch is turned by force.

## ■ Operation Mode

Operation mode	Light ON	Dark ON
Receiver operation	Received light Interrupted light	Received light Interrupted light
Operation indicator (red LED)	ON	ON
Transistor output (NPN/PNP)	OFF	OFF

## ■ Operation Timing Diagram

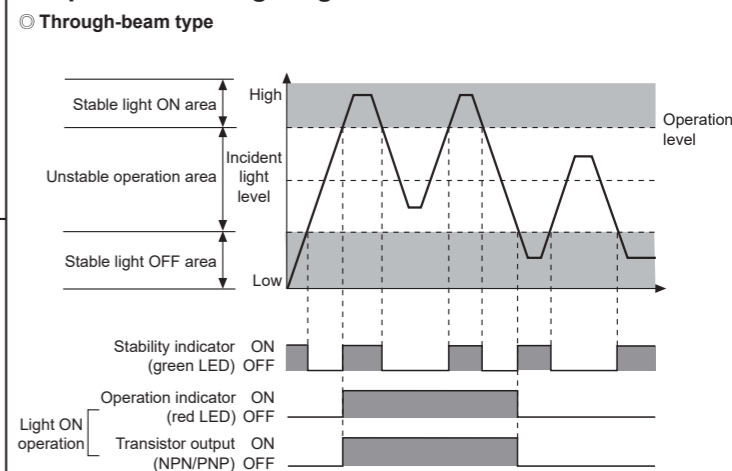

## • Retroreflective type / Diffuse reflective type

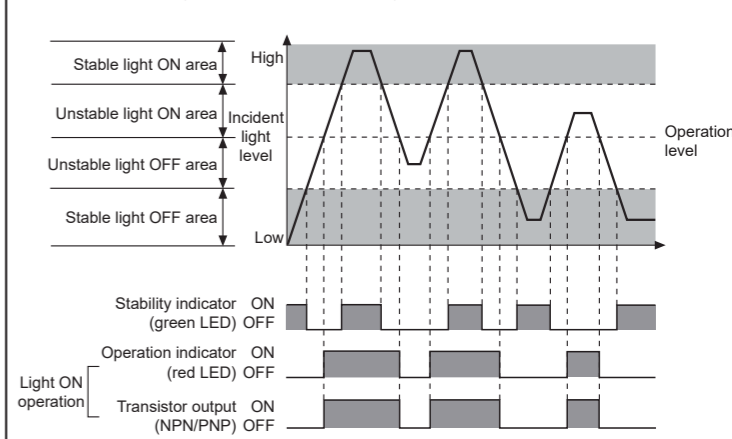

⚠ The waveforms of "Operation indicator" and "Transistor output" are for Light ON. The waveforms are reversed for Dark ON.

## ■ Cautions during Use

- Follow instructions in 'Cautions during Use'. Otherwise, it may cause unexpected accidents.
- When connecting a DC relay or other inductive load to the output, remove surge by using diodes or varistors.
- Use the product, 0.5 sec after supplying power. When using separate power supply for the sensor and load, supply power to sensor first.
- 12-24VDC power supply should be insulated and limited voltage/current or Class 2, SELV power supply device.
- Wire as short as possible and keep away from high voltage lines or power lines, to prevent inductive noise.
- When using switching mode power supply to supply the power, ground F.G. terminal and connect a condenser between 0V and F.G. terminal to remove noise.
- When using sensor with the equipment which generates noise (switching regulator, inverter, servo motor, etc.), ground F.G. terminal of the equipment.
- This unit may be used in the following environments.
  - ①Indoors (UL Type 1 Enclosure)
  - ②Altitude max. 2,000m
  - ③Pollution degree 3
  - ④Installation category II

## ■ Major Products

- Photoelectric Sensors
- Fiber Optic Sensors
- Door Sensors
- Door Side Sensors
- Area Sensors
- Proximity Sensors
- Pressure Sensors
- Rotary Encoders
- Connectors/Sockets
- Switching Mode Power Supplies
- Control Switches/Lamps/Buzzers
- I/O Terminal Blocks & Cables
- Stepper Motors/Drivers/Motion Controllers
- Graphic/Logic Panels
- Field Network Devices
- Laser Marking System(Fiber, Co2, Nd:YAG)
- Laser Welding/Cutting System
- Temperature Controllers
- Temperature/Humidity Transducers
- SSRs/Power Controllers
- Counters
- Timers
- Panel Meters
- Tachometers/Pulse(Rate)Meters
- Display Units
- Sensor Controllers

**Autonics Corporation**  
<http://www.autonics.com>

HEADQUARTERS:  
 18, Bansong-ro 513beon-gil, Haeundae-gu, Busan, South Korea, 48002  
 TEL: 82-51-519-3232  
 E-mail: sales@autonics.com