

## Common Terminal Block

# ACS Series

## INSTRUCTION MANUAL

DRW170726AD

**Autonics**

Thank you for choosing our Autonics product.

**Read and understand the instruction manual and manual thoroughly before using the product.**

**For your safety, read and follow the below safety considerations before using. For your safety, read and follow the considerations written in the instruction manual, other manuals and Autonics website.**

Keep this instruction manual in a place where you can find easily.

The specifications, dimensions, etc. are subject to change without notice for product improvement. Some models may be discontinued without notice.

Follow Autonics website for the latest information.

### Safety Considerations

- Observe all 'Safety Considerations' for safe and proper operation to avoid hazards.
- ▲ symbol indicates caution due to special circumstances in which hazards may occur.

**▲ Warning** Failure to follow instructions may result in serious injury or death.

**01. Fail-safe device must be installed when using the unit with machinery that may cause serious injury or substantial economic loss. (e.g. nuclear power control, medical equipment, ships, vehicles, railways, aircraft, combustion apparatus, safety equipment, crime/disaster prevention devices, etc.)**

Failure to follow this instruction may result in personal injury, economic loss or fire.

**02. Do not use the unit in the place where flammable/explosive/corrosive gas, high humidity, direct sunlight, radiant heat, vibration, impact, or salinity may be present.**

Failure to follow this instruction may result in explosion or fire.

**03. Do not connect, repair, or inspect the unit, or remove connector while connected to a power source.**

Failure to follow this instruction may result in fire or electric shock.

**04. Do not disassemble or modify the unit.**

Failure to follow this instruction may result in fire or electric shock.

**▲ Caution** Failure to follow instructions may result in injury or product damage.

**01. Use the unit within the rated specifications.**

Failure to follow this instruction may result in fire or product damage.

**02. Use dry cloth to clean the unit, and do not use water or organic solvent.**

Failure to follow this instruction may result in fire or electric shock.

**03. Keep the product away from metal chip, dust, and wire residue which flow into the unit.**

Failure to follow this instruction may result in fire or product damage.

**04. Do not use the product when a screw of terminal is loosened.**

Failure to follow this instruction may result in fire or product damage.

### Cautions during Use

- Follow instructions in 'Cautions during Use'. Otherwise, it may cause unexpected accidents.
- Keep away from high voltage lines or power lines to prevent inductive noise. In case installing power line and input signal line closely, use line filter or varistor at power line and shielded wire at input signal line. Do not use near the equipment which generates strong magnetic force or high frequency noise.
- This unit may be used in the following environments.
  - Indoors (in the environment condition rated in 'Specifications')
  - Altitude max. 2,000m
  - Pollution degree 2
  - Installation category II

### Ordering Information

This is only for reference.

For selecting the specific model, follow the Autonics web site.

ACS - ① ② ③

#### ① Terminal block arrangement

No-mark: single line

B: double line

#### ② The number of connector pin

20: 20-pin

40: 40-pin

50: 50-pin

#### ③ Common type

L: Left + COM, Right - COM

T: Top + COM, Bottom - COM

### Specifications

Model	ACS-20□	ACS-40□	ACS-B40□	ACS-50□
The number of terminal	20	40	40	50
Terminal type	Screw	Screw	Screw	Screw
Terminal block arrangement	Single line	Single line	Double line	Single line
Terminal pitch	7.0 mm	7.0 mm	7.2 mm	7.0 mm
Material	Case, Base: MPPPO, terminal: brass	Case, Base: MPPPO, terminal: brass	Case, Base: PC, terminal: brass	Case, Base: MPPPO, terminal: brass
Approval	CE	CE	CE	CE
Unit weight (packaged)	≈ 61 g (≈ 92 g)	≈ 115 g (≈ 157 g)	≈ 120 g (≈ 149 g)	≈ 141 g (≈ 189 g)
Rated voltage	≤ 125 VDC≐, 125 VAC~ 50/60 Hz			
Rated current	≤ 10 A			
Insulation resistance	≥ 1,000 MΩ (500 VDC≐ megger)			
Dielectric strength	2,700 VAC~ 50/60 Hz for 1 minute			
Vibration	0.75 mm amplitude at frequency of 10 to 55 Hz (for 1 minute) in each X, Y, Z direction for 2 hours			
Vibration (malfunction)	0.75 mm amplitude at frequency of 10 to 55 Hz (for 1 minute) in each X, Y, Z direction for 10 minutes			
Shock	150 m/s <sup>2</sup> (≈ 15 G) in each X, Y, Z direction for 3 times			
Shock (malfunction)	100 m/s <sup>2</sup> (≈ 10 G) in each X, Y, Z direction for 3 times			
Ambient temperature	-15 to 55 °C, storage: -25 to 65 °C (a non freezing or condensation environment)			
Ambient humidity	35 to 85 %RH, storage: 35 to 85 %RH (a non freezing or condensation environment)			
Protection structure	IP20 (IEC standard)			
Applicable wire - solid	∅ 0.3 to 1.2 mm			
Applicable wire - stranded	AWG 22-16 (0.30 to 1.25 mm <sup>2</sup> )			
Crimp terminal connection tensile strength	≥ 30 N			
Tightening torque	0.5 to 0.6 N·m			

### Crimp Terminal Specifications

- Unit: mm, Use the UL approved crimp terminal.

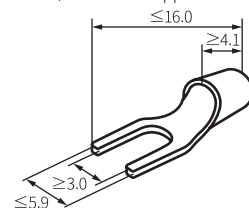

Fork crimp terminal

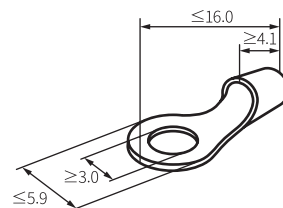

Round crimp terminal

### Dimensions

- Unit: mm, For the detailed dimensions of the product, follow the Autonics web site.

#### Single line

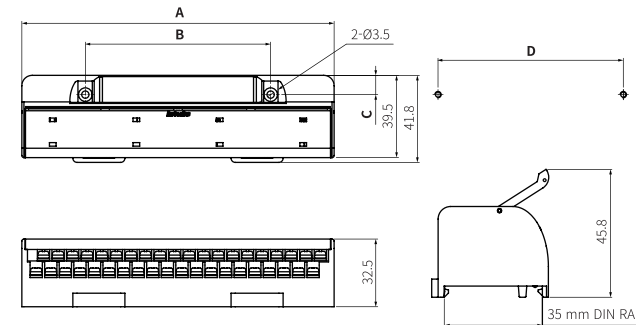

	A	B	C	D
20-pin	80	62.5	9.3	62.5
40-pin	150	89	9.3	89
50-pin	184	104	8.8	104

#### Double line

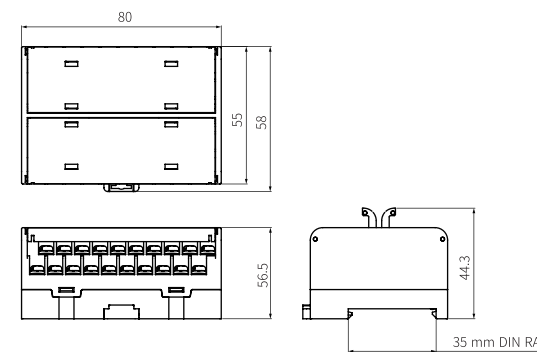

### Installation

#### DIN RAIL

- Mounting

- Pull the Rail lock on the rear of the product to the direction ①.
- Hang DIN rail hook on the rear of the product onto DIN rail.
- Push the product to the direction ②, and push the Rail lock to the direction ③ to fix onto the DIN rail.

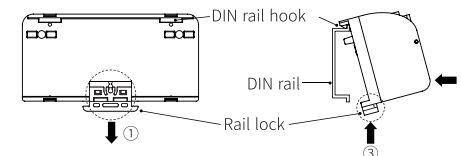

- Removing

- Insert a tool such as screwdriver into the hole of Rail lock.
- Push the toll to the direction ① and pull the Rail lock.
- Lift bottom of the product to the direction ② and remove the product from DIN rail.

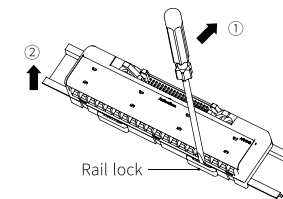

#### Panel

Product with the mounting hole can be installed on panel with screw.

It is recommended to use M3×30 mm of spring washer screws.

If you use flat washer, its diameter should be ∅ 6 mm.

Tighten the screw with the tightening torque of 0.5 to 0.7 N·m.

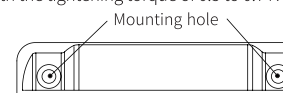

### Wire Connection

- ACS-20L

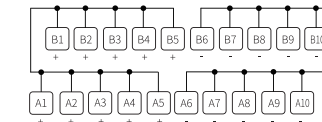

- ACS-20T

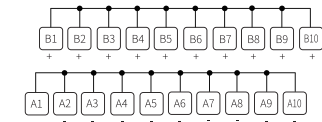

- ACS-40L

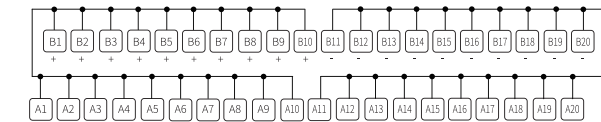

- ACS-40T

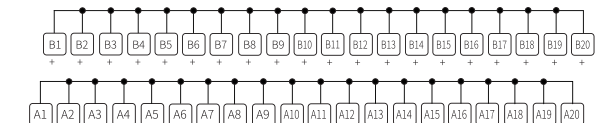

- ACS-B40L

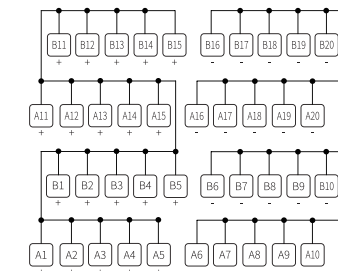

- ACS-B40T

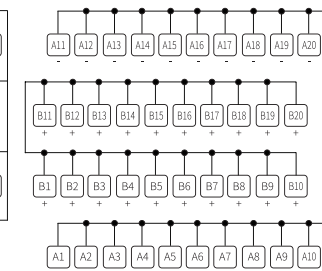

- ACS-50L

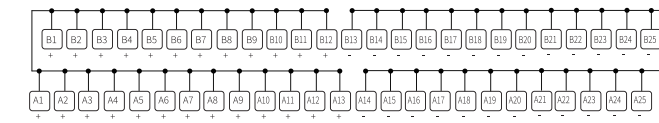

- ACS-50T

