



**MUTUAL MOTOR**

Mutual motor technology

**产品规格承认书**

客户(Customer): \_\_\_\_\_

送样日期(Sample Issue Date): \_\_\_\_\_

规格(Description): 120\*120\*38MM

版本(Edition): \_\_\_\_\_

型号(Model No): M115BA1/A2 HB

<b>客户承认栏</b> CONFIRMATION SIGNATURE	<b>美途确认栏</b> MUTUAL SIGNATURE		
<div data-bbox="229 1335 687 1525" style="border: 1px solid black; padding: 5px; text-align: center;">本承认书内容若贵司确认无误, 请于上方承认栏内签章寄回. Please confirm your acceptance of this approval sheet by return fax.</div>	<b>核准</b> APPD.	<b>审核</b> EDAM.	<b>制表</b> DRAW.

**东莞市美途电机科技有限公司**

DONGGUAN MUTUAL MOTOR TECHNOLOGY CO.,LTD

电话: 0769-82205666

传真: 0769-83720788

-----

[www.mutualmotor.com](http://www.mutualmotor.com)  
**PRODUCT SPECIFICATION**  
**APPROVAL SHEET**

一、 样品规格(Sample Specification):

项目 (Item)		规格/条件 (Specification/Condition)	
01	型号 Part No.	M115BA1HB M115BA2HB	
02	外形尺寸 (Outline Dimension)	120mm*120mm*38mm	
03	额定电压 (Rated Voltage)	AC 110V/220V	
04	电压范围 (Voltage Range)	AC 100V~130V/200~240V	
05	频率 (Frequency)	60/50Hz	
06	额定电流 (Rated Current)	0.23A/0.14A±0.02A	25°C 60~80RH
07	消耗功率 (Power Consumption)	17W/20W±10%	25°C 60~80RH
08	转速 (Speed)	3000/2600RPM±10%	25°C 60~80RH
09	最大风量 (Max. Air flow)	103/85CFM±10%	25°C 60~80RH 額定電流 (Rated Current)
10	最大静压 (Max. Static Pressure)	0.34/0.28INCH-H2O	
11	噪音 (Noise Level)	49/43dB (A)	
12	重量 (Weight)	520g	

二、 电气规格(Electrical Specification):

项目 (Item)		规格/条件 (Specification/Condition)	
01	绝缘耐压 (Dielectric Strength)	外框与导线之间施加交流 1800V /1 秒,测定漏电流最大 0.5mA。 Max. 0.5mA between frame and lead wire at 1800V for 1s.	
02	绝缘阻抗 (Insulation Resistance)	框与导线之间施加直流 500VDC /1 分钟,测定最小阻抗 100MΩ。 Min.100MΩ between frame and lead wire at 500VDC for 1minute.	
03	运转温升 (Temperature Test of Run)	在额定电压和室温温度,电机绕组温升最大 80K。 At Rated Voltage, Δt<80K	
04	锁定检测 (Locked Rotor Protection)	在使用温度和使用电压条件下,通电锁住转子72小时,无烧损发生。The rotor is kept locking for 72 hours at the range of operating temperature and operating voltage. No burn must occur.	

三、 安规情况(Safety Approvals):

安规 (Safety Approvals)	安规编号 (File No)	安规 (Safety Approvals)	安规编号 (File No)
UL	E343775	CE	E8A170475910005
CUL	E343775	CCC	W-0355-20CNL
TUV	E8A170475910006		

#### 四、环境条件(Environmental Specification):

项目(Item)		规格/条件(Specification/Condition)
01	工作温/湿度范围(Operating Temp. Range)	温度(Temperature): -20°C~65°C 湿度(Humidity): 20%~85%RH
02	保存温/湿度范围(Storage Temperature)	温度(Temperature): -30°C~85°C 湿度(Humidity): 20%~95%RH
03	寿命(Life)	50000H

#### 五、 主要材料/零件规格(Main Materials/Parts Specification):

项目(Item)		规格(Specification)
01	扇叶(Blade)	热塑性(PBT) PBT+15%GF
02	框架(Frame)	高质量铝合金外框防腐防湿结构(Aluminum ADC-12, Painted Black)
03	定子与转子(Stator& Rotor)	矽钢 H23(Silicon steel H23)
04	漆包线(Magnet Wires)	Copper 1 UEW
05	绝缘套(Bobbin)	PA-66 UL 94 V-0
06	轴承类型 (Bearing Type)	NMB 830#LY551 滚珠轴承(Ball Bearing)

#### 六、 商标说明(Label Marking):

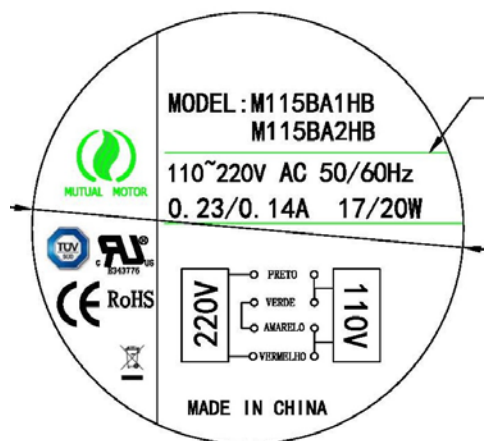

序号 (Ordinal)	说明 (Explain)
1	风扇型号 (Model)
2	版本 (Edition)
3	电压 频率 (Voltage /Frequency)
4	功率 电流 (Current /Consumption)
5	轴承 类型 (Bearing Type)
6	滚珠轴承(Ball Bearing)
7	含油轴承 ( Sleeve Bearig)
8	阻抗受保护 ( Impedance protected)
9	生产地 ( Producer)
10	安规 ( Safety Approvals)

#### 型号说明(Model Explain):

**M115BA2HB**

- Bearing Type(培林类型): B-Ball Bearing(滚珠轴承), S-Sleeve Bearing(含油轴承);
- Motor Speed(马达转速): H-High Speed(高转), M-Middle Speed(中转), L-Low Speed(低转);
- Rated Voltage(额定电压): A1-110VAC, A2-220VAC, A3-380VAC;
- Housing Thickness(厚度): A-25mm, B-38mm, C-51mm, D-55mm, E-60mm;
- Square Frame(方形框架): 120mm\*120mm;
- Company Code(公司代码): M-MUTUAL(美途)。

七、外观尺寸图(Outline Dimension):

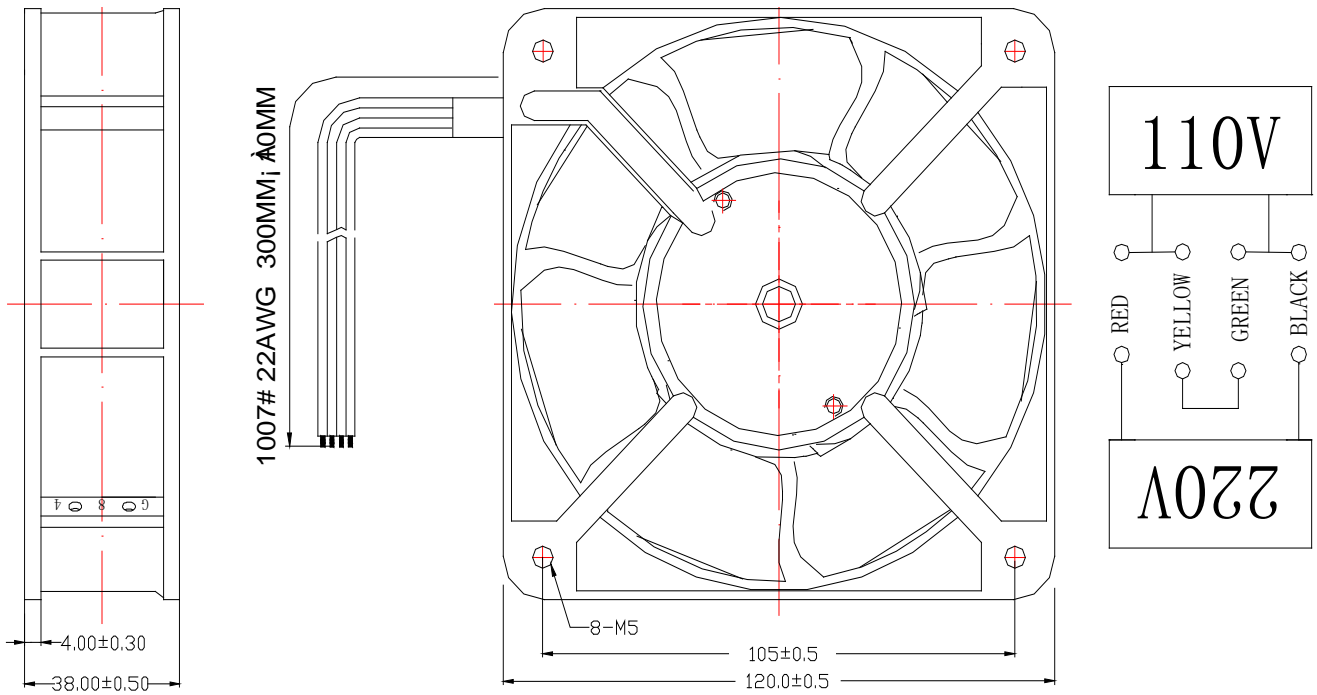

八、特性图(Property):

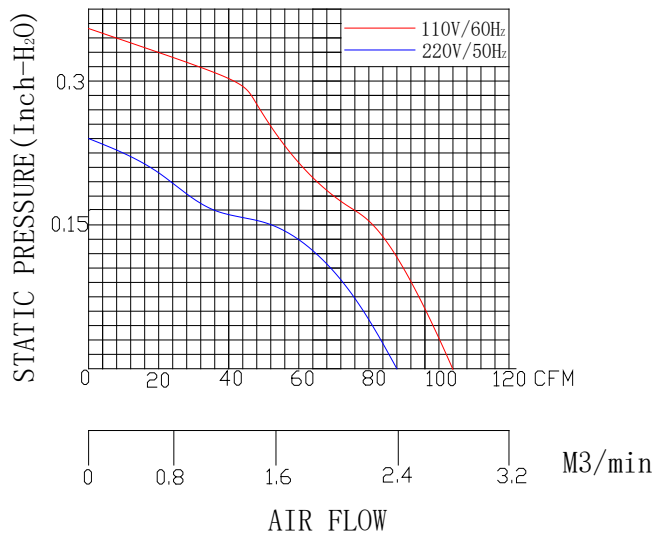

**Above specification is only for reference and subject to change without notice.**

以上数据仅供参考，如有变更恕不另行通知。