



MUTUAL MOTOR

Mutual motor technology

产品规格承认书

客户(Customer): _____

送样日期(Sample Issue Date): _____

规格(Description): 80*80*25mm

版本(Edition): A

型号(Model No): M075AA2HS

| 客户承认栏 CONFIRMATION SIGNATURE | 美途确认栏 MUTUAL SIGNATURE | | |
|---|---|-------------|-------------|
| <div style="border: 1px solid black; padding: 5px; text-align: center;">本承认书内容若贵司确认无误, 请于上方承认栏内签章寄回。 Please confirm your acceptance of this approval sheet by return fax.</div> | 核准 APPD. | 审核 EDAM. | 制表 DRAW. |
| | | | |

东莞市美途电机科技有限公司

DONGGUAN MUTUAL MOTOR TECHNOLOGY CO.,LTD

电话: 0769-82205666

传真: 0769-83720788

地址: 广东省东莞市横沥镇新城工业区兴业大道

Add : Metro Industrial Park,Industrial Avenue,Hengli Town,Dongguan City,Guangdong

www.mutualmotor.com

产品规格承认书

**PRODUCT SPECIFICATION
APPROVAL SHEET**

一、 样品规格(Sample Specification):

| 项目(Item) | | 规格/条件(Specification/Condition) | |
|----------|----------------------------|--------------------------------|--------------------------------------|
| 01 | 型号 Part No. | M075AA2HS | |
| 02 | 外形尺寸(Outline Dimension) | 80mm*80mm*25mm | |
| 03 | 额定电压(Rated Voltage) | AC 110/220V | |
| 04 | 电压范围(Voltage Range) | AC 100V~130V/200V~240V | |
| 05 | 频率(Frequency) | 60/50Hz | |
| 06 | 额定电流(Rated Current) | 0.11/0.06A±10% | 25℃ 60~80%RH |
| 07 | 消耗功率(Power Consumption) | 10/12.5W±10% | 25℃ 60~80%RH |
| 08 | 转速(Speed) | 3050/2550RPM±10% | 25℃ 60~80%RH |
| 09 | 最大风量(Max. Air flow) | 38/33CFM±10% | 25℃ 60~80%RH 额定电流 (Rated Current) |
| 10 | 最大静压(Max. Static Pressure) | 0.19/0.14Inch-H2O | |
| 11 | 噪音(Noise Level) | 35/33dB(A) | |
| 12 | 重量(Weight) | 230g | |

二、 电气规格(Electrical Specification):

| 项目(Item) | | 规格/条件(Specification/Condition) | |
|----------|-----------------------------------|---------------------------------|--|
| 01 | 绝缘耐压 (Dielectric Strength) | 1800V/0.5mA/3s | |
| 02 | 绝缘阻抗 (Insulation Resistance) | 阻抗保护 Impedance protected | |
| 03 | 运转温升 (Temperature Test of Run) | Δt=<70℃ 额定电压(Rated Voltage) | |
| 04 | 锁定检测 (Locked Rotor Protection) | Δt=<130℃ 额定电压(Rated Voltage) | |

三、 安规情况(Safety Approvals):

| 安规 (Safety Approvals) | 安规编号 (File No) | 安规 (Safety Approvals) | 安规编号 (File No) |
|--------------------------|-------------------|--------------------------|--------------------|
| UL | E343775 | RoHS-TUV | 68.160.10.00583.01 |
| CUL | N/A | CCC | 2013010401594874 |

| | | | |
|--------|-------------------|--------|-------------------|
| TUV | E8N 101275910 002 | CE | N810 12 75910 001 |
| TUV-GS | N/A | C-Tick | N/A |

四、环境条件(Environmental Specification):

| 项目(Item) | 规格/条件(Specification/Condition) |
|-------------------------------------|--|
| 01 工作温/湿度范围 (Operating Temp. Range) | 温度 (Temperature): -20°C~65°C 湿度 (Humidity): 20%~85%RH |
| 02 保存温/湿度范围 (Storage Temperature) | 温度 (Temperature): -30°C~85°C 湿度 (Humidity): 20%~95%RH |
| 03 寿命 (Life) | 20000H |

五、主要材料/零件规格(Main Materials/Parts Specification):

| 项目(Item) | 规格(Specification) |
|--------------------------|---|
| 01 扇叶 (Blade) | 热塑性 (PBT) PBT+15%GF |
| 02 框架 (Frame) | 高质量铝合金外框防腐防湿结构 (Aluminum ADC-12, Painted Black) |
| 03 定子与转子 (Stator& Rotor) | 矽钢 (Silicon steel) |
| 04 漆包线 (Magnet Wires) | Copper 2 UEW |
| 05 绝缘套 (Bobbin) | PA-66 UL 94 V-0 |

六、商标说明(Label Marking):

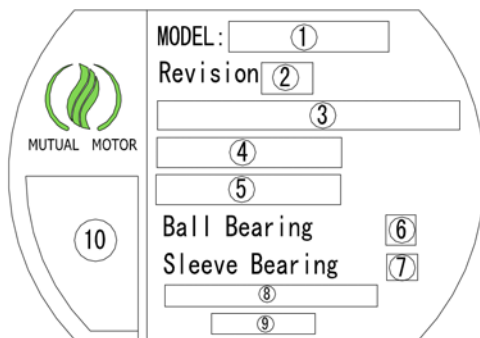

| 序号 (Ordinal) | 说明 (Explain) |
|--------------|-------------------------------|
| 1 | 风扇型号 (Model) |
| 2 | 版本 (Edition) |
| 3 | 电压 频率 (Voltage /Frequency) |
| 4 | 功率 电流 (Current /Consumption) |
| 5 | 轴承 类型 (Bearing Type) |
| 6 | 滚珠轴承 (Ball Bearing) |
| 7 | 含油轴承 (Sleeve Bearig) |
| 8 | 阻抗受保护 (Impedance protected) |
| 9 | 生产地 (Producer) |
| 10 | 安规 (Safety Approvals) |

cc

型号说明(Model Explain):

M075AA2HS

| | |
|---|---|
| — | Bearing Type(培林类型): B-Ball Bearing(滚珠轴承), S-Sleeve Bearing(含油轴承); |
| — | Motor Speed(马达转速): H-High Speed(高转), M-Middle Speed(中速), L-Low Speed(低转); |
| — | Rated Voltage(额定电压): A1-120VAC, A2-220VAC, A3-380VAC; |
| — | Housing Thickness(厚度): A-25mm, B-38mm, C-51mm, D-55mm, E-60mm; |
| — | Square Frame(方形框架): 80mm*80mm; |
| — | Company Code(公司代码): M-MUTUAL (美途)。 |

七、 外观尺寸图(Outline Dimension):

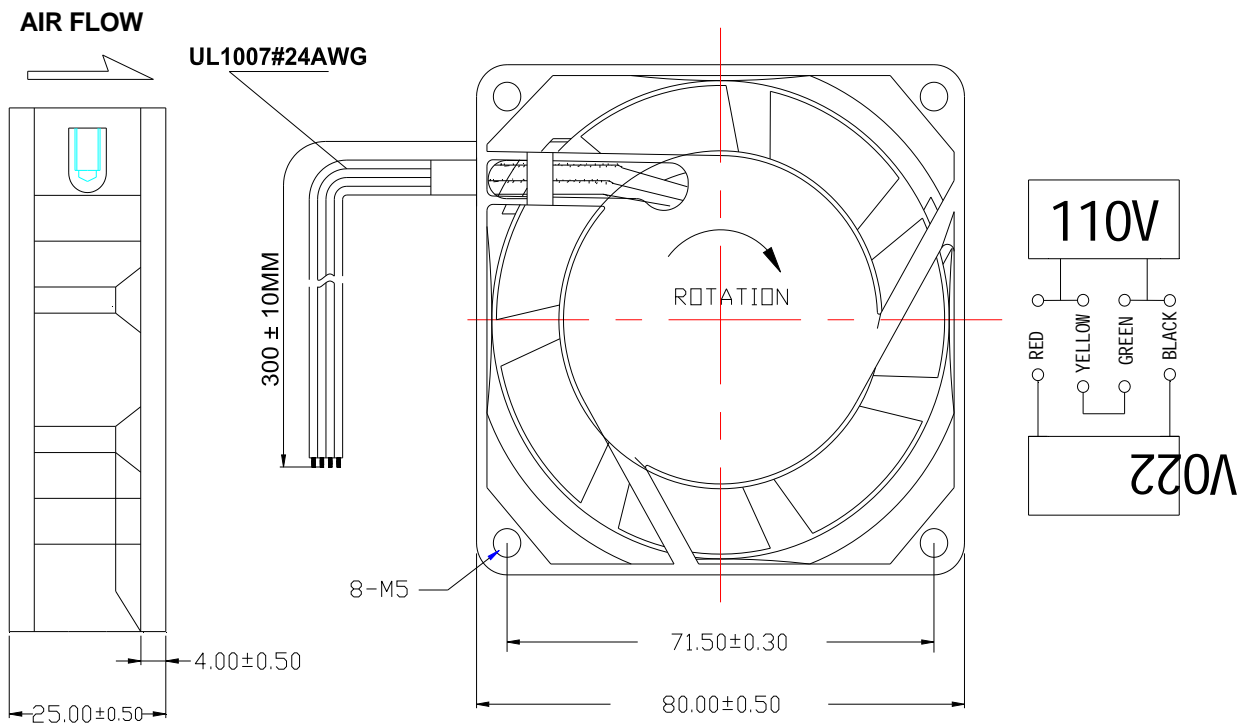

八、 特性图(Property):

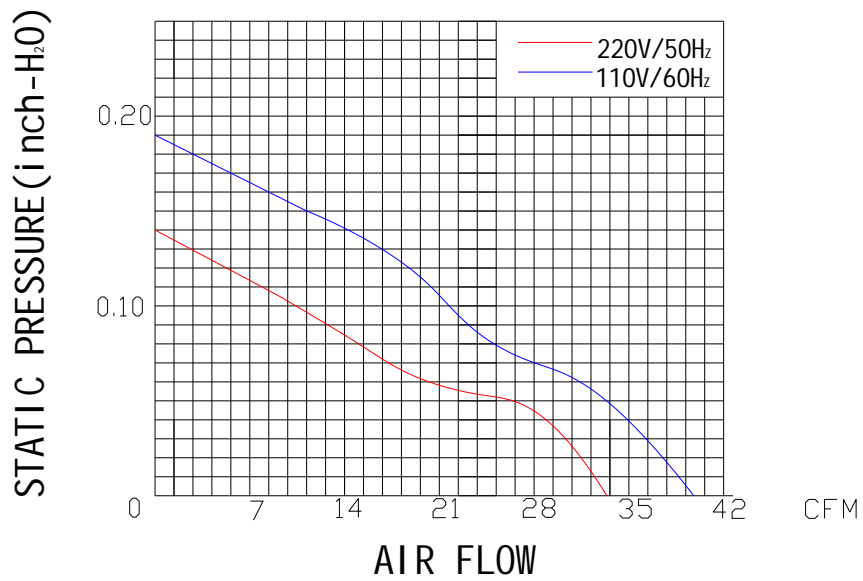

Above specification is only for reference and subject to change without notice.

以上数据仅供参考，如有变更恕不另行通知。